

Evaluation of Parameters Used in Progressive Damage Models

Fall 2019

David Plechaty, Satish Solanki

& John P. Parmigiani,
Oregon State University

Key Aspects

Motivation and Key Issues

- The matrix-compression material-model used in Abaqus for carbon fiber laminates is computationally efficient but is physically unrealistic and does not correspond to actual material behavior.

Objective

- Determine the conditions under which the use of this unrealistic material model causes significant errors in predictions of carbon fiber laminate response to load and load-carrying ability.

Approach

- Conduct experimentation to determine a physically-correct matrix-compression material model
- Implement this material model in Abaqus and compare its predictions with those of the currently-used material model

Personnel

- **Principal Investigators & Researchers**
 - John Parmigiani (PI); OSU faculty
 - D. Plechaty, S. Solanki; OSU grad students
- **FAA Technical Monitor**
 - Ahmet Oztekin
 - Lynn Pham
- **Other FAA Personnel Involved**
 - Larry Ilcewicz
- **Industry Participation**
 - Kazbek Karayev, Boeing
 - Gerry Mabson, Boeing
 - Jonathan Lusk, Boeing

Today's topics

- Introduction
 - The problem to be solved
 - Our Prior work
 - Today's new content
- Experimental Methods and Results
- Computational (FEA) Methods

Evaluation of Parameters used in Progressive Damage Models

Introduction: The problem to be solved

- Currently Abaqus uses the same triangular material model for both matrix tension and compression
 - Origin-to-A is linear elastic
 - Point A determined by Hashin criteria
 - A-to-B is linear. B defined by the constant area-under-curve toughness G_{mt} and G_{mc}
- This model is computationally convenient and is appropriate for matrix tension
- Our thinking from this project's beginning was that this model is not accurate for matrix compression

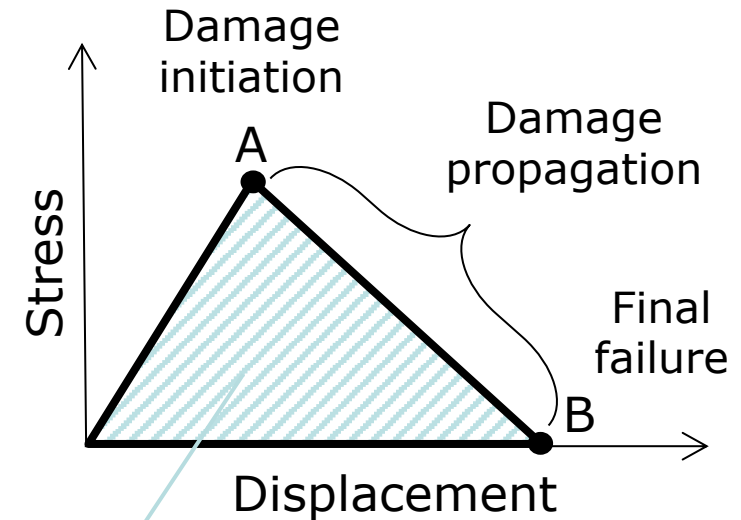

Area = toughness G_{mt} or G_{mc}

Evaluation of Parameters used in Progressive Damage Models

Introduction: Our Prior Work

- Our prior work includes creation of a test specimen to isolate matrix compression damage propagation
- Specimen stress-displacement relationship
 - Origin-to-A is linear elastic
 - Point A is crack initiation at notch tip
 - A-to-B is “instantaneous” crack growth
 - B-to-C is stable crack propagation from a sharp crack tip
 - Point C is eventual tensile failure of “back side”
- A & B are specific to specimen
- B-to-C governed by material property G_{mc}

$$G_{mc}^{observed} = G_{mc}^{tip} + G_{mc}^{wake}$$

$$G_{mc}^{tip} \neq f[a]$$

$$G_{mc}^{wake} = f[a]$$

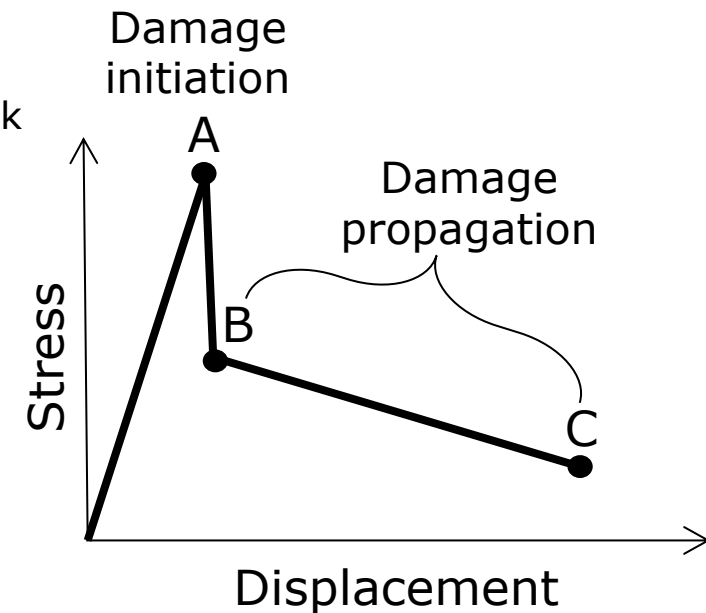
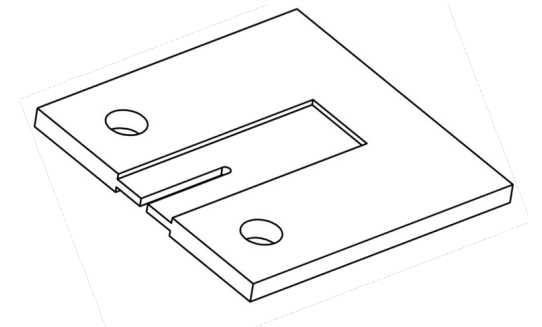

Evaluation of Parameters used in Progressive Damage Models

Introduction: The problem to be solved

- A key tension-vs-compression difference is the area-under-curve toughness G_{mt} and G_{mc}
 - For **tension** a constant value is reasonable. G_{mt} is a function of
 - Crack surface area creation
 - Process zone ahead of the crack tip
 - For **compression** a constant value is not reasonable. G_{mc} is a function of
 - Crack surface area creation
 - Process zone ahead of the crack tip
 - Load carried in the crack wake
- A realistic matrix compression material model must include R-Curve behavior

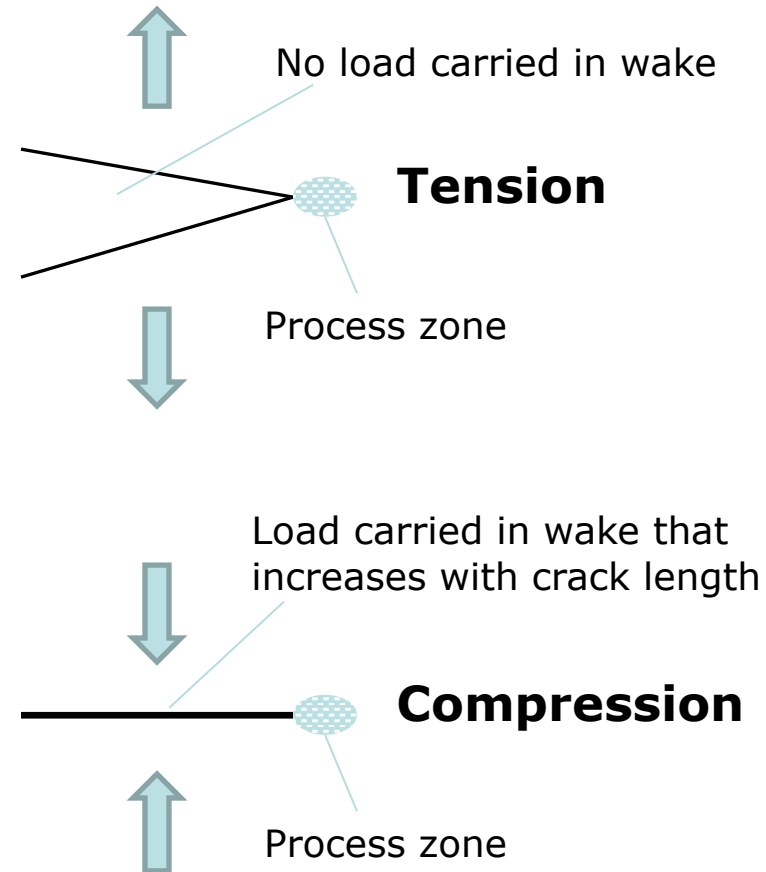

Introduction: Today's new content

- Experimental Methods and Results
 - Test Procedures
 - Analysis Methods
 - Results
- Computational (FEA) Methods
 - Objective and Milestones
 - Approach
 - Modeling Methods
 - Results

Experimental Methods and Results

Testing Procedures

- To isolate and collect matrix compression propagation data a new testing procedure was required. From previous experiments the following parameters were determined.
 - The use of the Compact Compression (CC) specimen with a 0.875" notch length.
 - Tests conducted at a displacement rate of 1 mm/min.
 - Two cameras to capture crack propagation required for analysis.
 - Loading the specimen until crack initiation occurs to produce sharp crack tip then unload.
 - Periodic loading-unloading to capture accurate damage propagation data. (required for data analysis using area method)

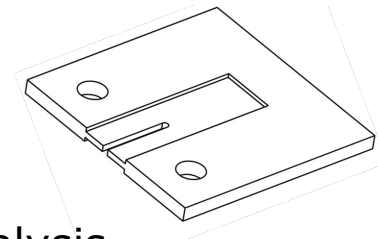

Evaluation of Parameters used in Progressive Damage Models

Testing Procedures

With the use of these parameters a testing procedure was developed. This procedure consisted of:

- Loading the specimen until damage initiation occurs then unloading specimen back to 0.2 mm displacement.
- Reloading specimen until damage propagation occurs and then manually unload specimen back to 0.2 mm displacement
- This process is repeated 2 times if possible or until tensile failure occurs on the back edge of specimen.

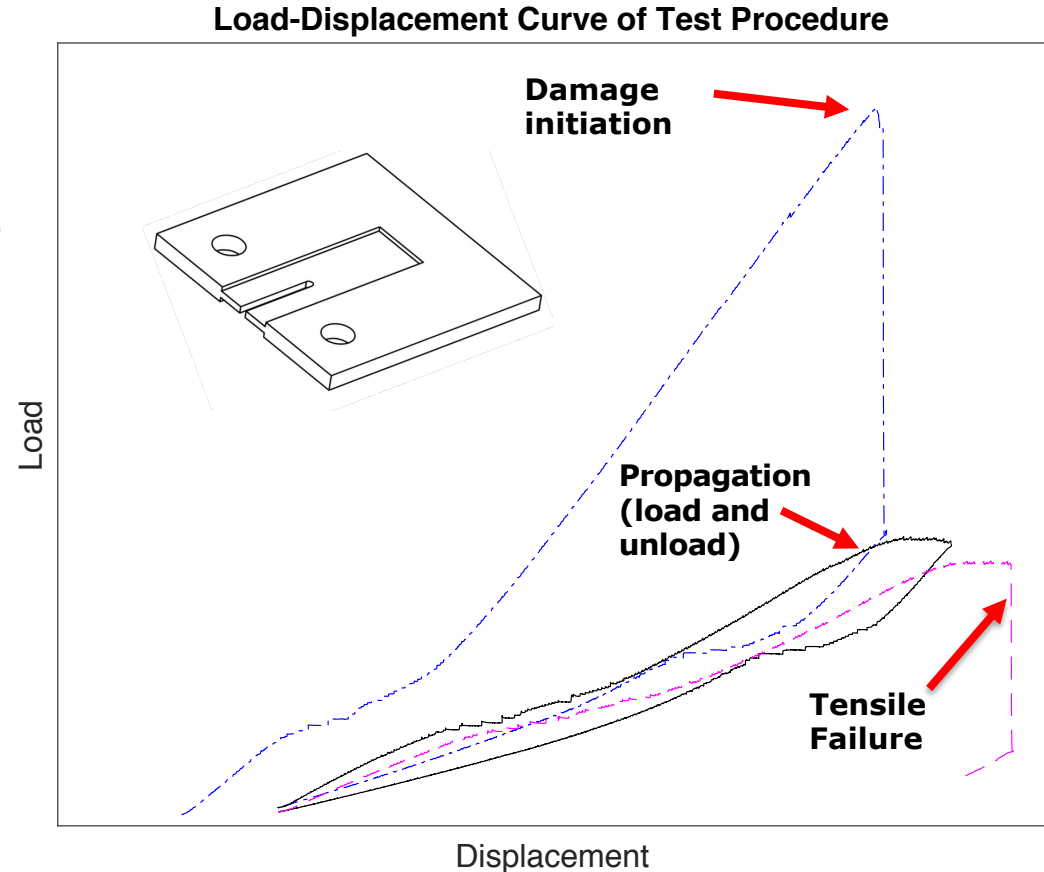

Evaluation of Parameters used in Progressive Damage Models

Testing Procedures

- From the multiple iterations of testing procedures various requirements specific to matrix compression propagation were observed. These key elements were:
 - Starter cracks which are flat cracks placed across the width of the specimen's damage region, could not be used due to complex "V" or "W" crack surfaces (shown in figure) created from matrix compression damage.
 - Specimens need to be unloaded during the propagation phase to ensure proper crack extension measurements.
 - With the current testing machine sample unloading had to be manually controlled due to software limitations.
- Modified test procedures minimized amount of times specimens had to be preloaded to once, while isolating matrix compression propagation.
- As this method minimizes most concerns, all further propagation tests will be conducted following this procedure.

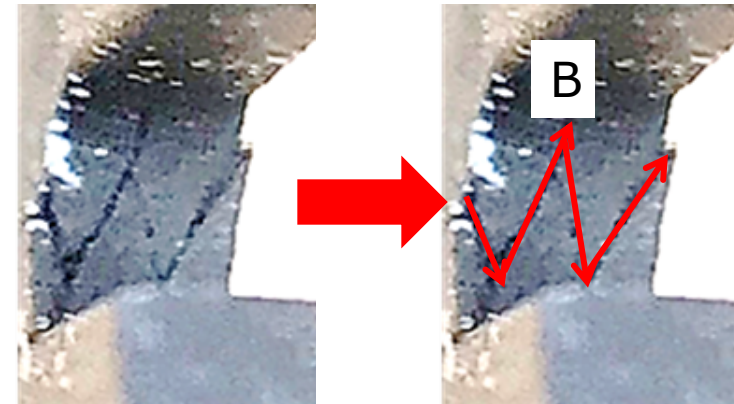

Image of the actual fracture surface width B due to matrix compression. (fracture surface width is shown by the red line path).

Analysis Methods

Area Method:

To determine fracture toughness the area method was used. This method requires the specimen to be loaded and unloaded periodically to get energy released during crack growth.

$$G_c = \frac{\Delta U}{B * \Delta a}$$

ΔU = The area enclosed by the load-unload cycle shown which is energy released from damage propagation. (shaded in grey)

B = Fracture surface width (measured optically using pixel scaling)

Δa = Crack extension (measured optically using pixel scaling)

Typical Propagation Load/Unload Load-Displacement Curve

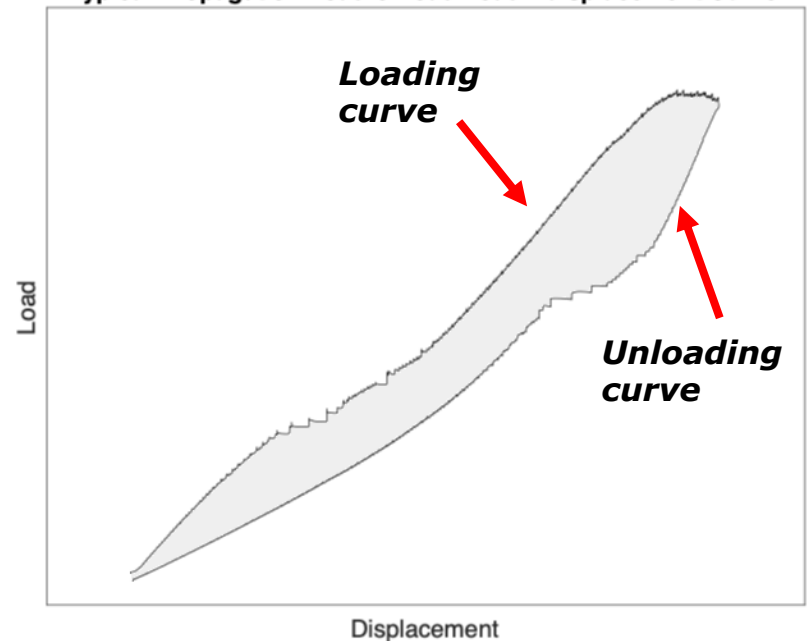

Analysis Methods

Crack Extension Measurement Method:

- The crack extension, da , was determined optically. The cameras recording the specimen during the test, captured the initial crack formed. This crack tip was in the vicinity of a particular speckle pattern. After the test was complete, this particular pattern was found on the specimen, and measured using image software.
- This is done by measuring a known length to get the pixels per length measurement, then measuring the crack pixel length to get the correct crack extension length.
- This measuring method is also used to measure the fracture surface width (B).

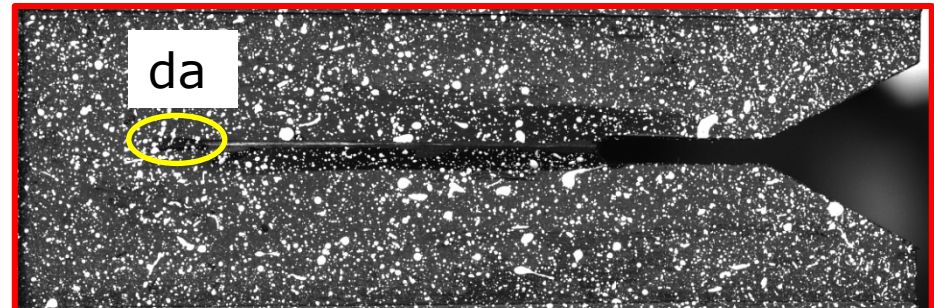
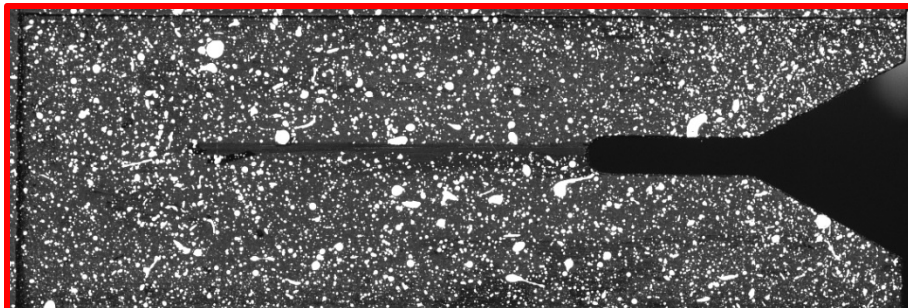

Analysis Methods

Fracture Surface Width Measurement Method:

- As with crack length, the crack surface widths were measured following the same method as previously stated.
- The reason for this is because the crack occurred at angles such as the “V” or “W” formations shown (below to the right). So the specimen thickness, alone, could not be used as the entire crack surface width needed to be measured.
- For this reason the crack surface widths were measured using the same software methods as stated in slide before.

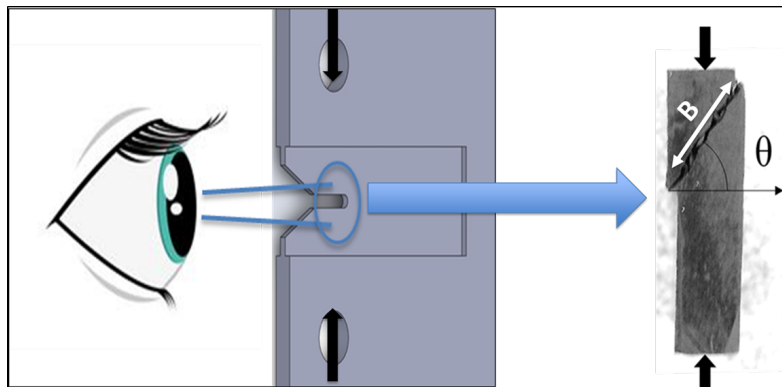

Results

Fracture Toughness Analysis:

- Using the test procedure and the area method, fracture toughness values for each specimen were obtained for an intermediate crack length.
- Results show the calculated energy release rate is 8.82 times larger than currently used value. Note this is the observed value which is affected by the G_{mc}^{wake} , which is a function of crack length a .
- Future work looks to define G_{mc}^{wake} functional relationship.
- To further improve this calculation more specimens are being tested using the testing procedures and analysis methods specified.

Computational (FEA) Methods

Objective and Milestones

Objective:

- Implement new material model for matrix compression in Abaqus and compare its predictions with the results of the current material model (Hashin Damage Model).

Milestones:

1. Simulate the compact compression experiment in Abaqus using current material model (Hashin damage model) and compared with experimental results.
2. Implement new material model into Abaqus using user subroutines and compare to experiment result.
3. Implement new material model to a generic layup laminate and evaluate its capability.

Today's discussion will cover the first milestone.

Approach

- To build a simulation model, the following were required:
 - Geometry
 - Material Properties
 - Mesh and element type
 - Boundary Conditions
 - Finite Element Solver

Modeling Methods

- Geometry:
 - The CC specimen geometry was created.
 - To apply load, loading pins were created.
 - The geometry of modeled specimen has same notch length (0.875 inch) as used in experiments.
- Material Properties:
 - Boeing composite material properties and layup were assigned to the composite specimen.
 - Hashin failure criteria was defined to specimen using toughness and strength values of the fiber and the matrix.

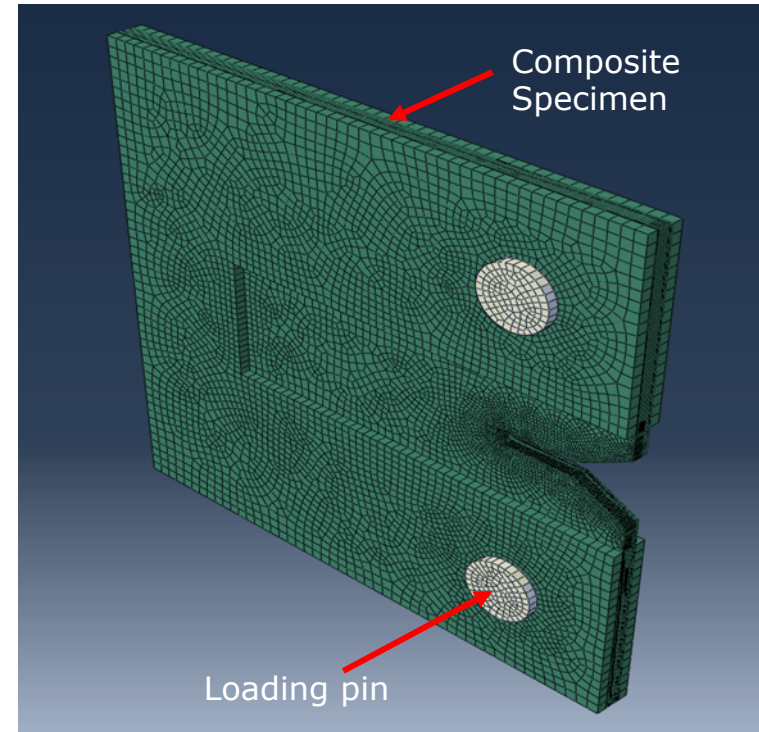
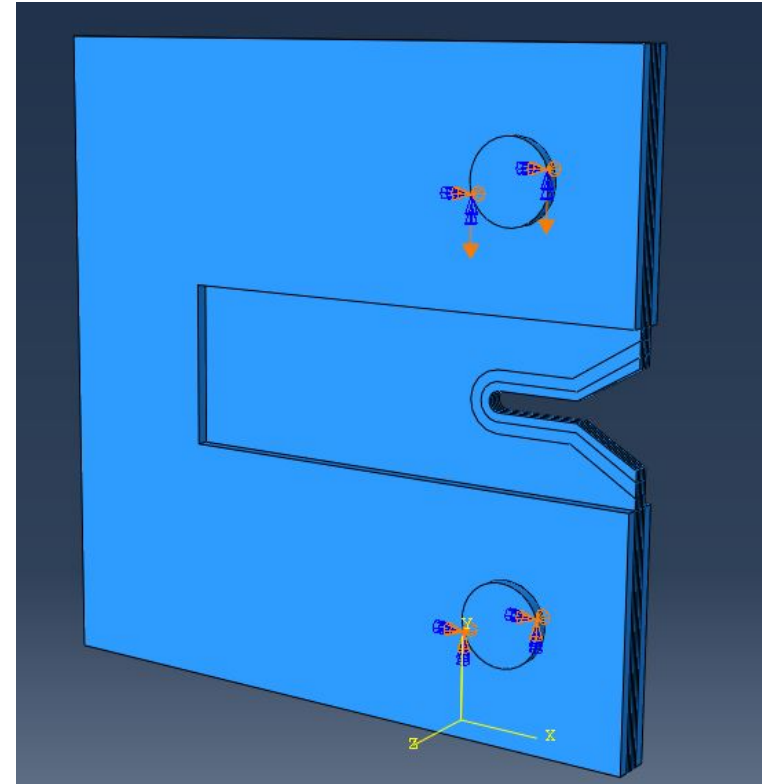

Figure: Modeled Stepped Compact Compression Specimen Geometry

Modeling Methods

- Mesh and element type
 - Composite Specimen and Loading pins were meshed using sweep type.
 - The loading pin was modeled using solid continuum with 8 node linear brick elements (C3D8R).
 - Hashin damage model is not available with 3D solid element in Abaqus. Hence continuum shell element of 8 node and reduced integration (SC8R) were used for composite specimen.
- Apply Boundary Conditions
 - The downward displacement boundary condition is imposed on the top loading pin while the bottom loading pin is fixed.
- Submit the job for FEA solver
 - Abaqus Explicit solver was used with mass-scaling to reduce simulation time.



Results

- Difference in current model and experiment result:
 - The simulation result (dashed curve) has more stiffness (slope of load-displacement curve) compared to experiment result (Solid curve).
 - The load at the crack initiation point from Hashin model is significantly lower than experiment result.
 - Hashin damage model results shows gradual crack propagation, whereas in the experiment, we observe instantaneous crack propagation.

Abaqus Result Vs Experiment Result

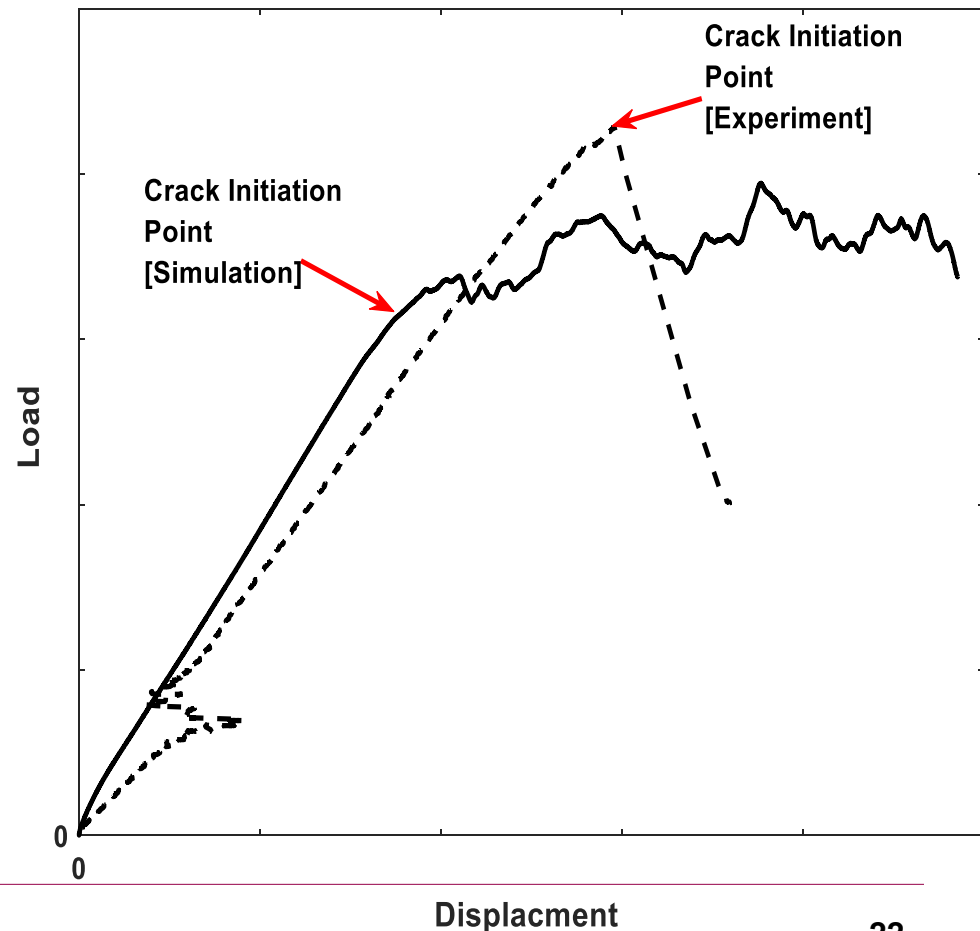

Results

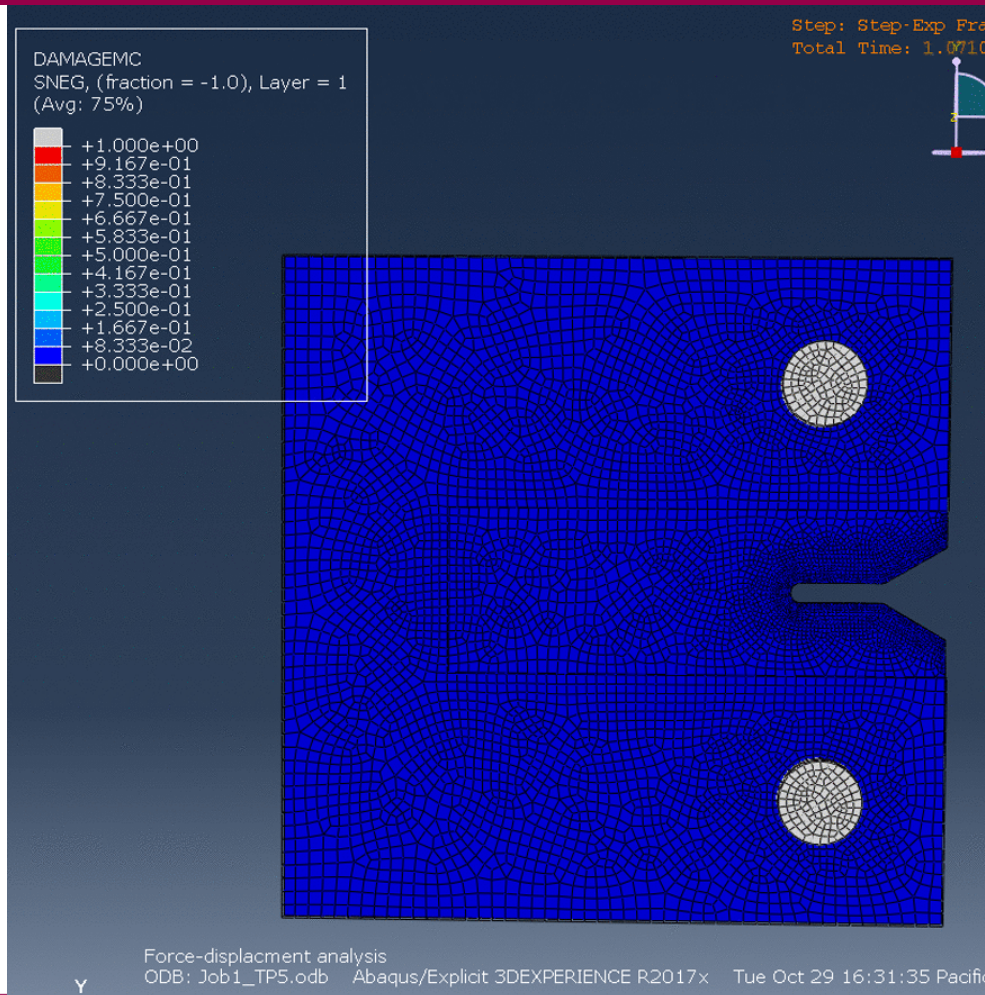

Results

- Based on simulation results, Hashin damage model is not suitable to model the crack propagation behavior in matrix under compression loading.
- As previously described there are two parts to the strain energy release rate.

$$G_{mc}^{observed} = G_{mc}^{tip} + G_{mc}^{wake}$$
$$G_{mc}^{tip} \neq f[a]$$
$$G_{mc}^{wake} = f[a]$$

- To start a simple model will be explored using the following equation

$$G_{mc}^{observed} = G_{mc}^{tip} + C*a$$

Future Work

- We have developed and determined:
 - Testing procedures and analysis methods for matrix compression.
 - Hashin Damage model is not applicable to model matrix compression.
- Looking Forward:
 - Test more specimens to
 - Investigate and further define $G_{mc}^{observed} = G_{mc}^{tip} + G_{mc}^{wake}$ behavior
 - Determine statistical variation of parameters
 - Implement new material model in Abaqus using user subroutines and compare to experimental results.

Questions?

Additional Slides

Current Material Model

- Hashin Damage model considers four different damage initiation mechanisms: fiber tension, fiber compression, matrix tension, and matrix compression.
- Once damage initiation has occurred for at least one mode of failure, the stiffness of element degrades gradually.
- Using Hashin's Theory, the current compact compression specimen was modeled in Abaqus using the given parameters for Boeing material.

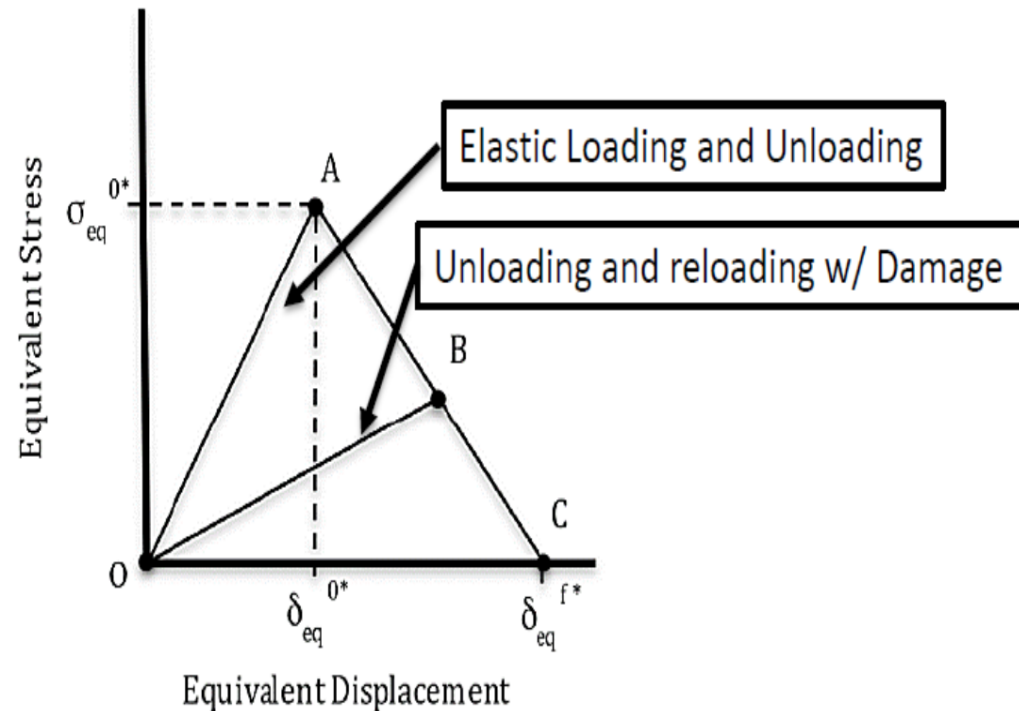

User Subroutines

User Subroutine:

(V)USDFDL, (V)UMAT are primary typically used when complex material behavior needs to be modeled.

(V)UMAT

- When none of the existing material model in Abaqus library represent accurately.
- Can define a model to calculate stress and strain.

(V)USDFDL

- When complex material behavior needed to be modeled.
- It allow users to define extra field variable at a material point as a function of quantities available at material point like stress and strain.

Due to the complexity of the (V)UMAT, the user subroutine (V)USDFDL will be explored.

Starter Crack Tests

- With a suitable specimen and mass manufacturing method, testing procedures for matrix compression propagation were required to determine the material's fracture toughness. To begin compact tension literature was explored due to the very limited literature on compact compression.
- It was found that most compact tension specimens have a sharp starter crack placed into the specimen with either a diamond wheel saw, razor saw, or a razor blade to get fracture toughness values for tension. With this in mind it was decided to introduce starter cracks into the specimens to see if these will help the focus on matrix compression propagation.
- Matrix compression tests were conducted at displacement rate of 1 mm/min using specimens with either
 - a 0° fracture-angle starter crack
 - a 45° fracture-angle starter crack
 - no starter crack (baseline). Baseline specimens were tested to have a direct comparison.
- All starter cracks were made with a razor saw.

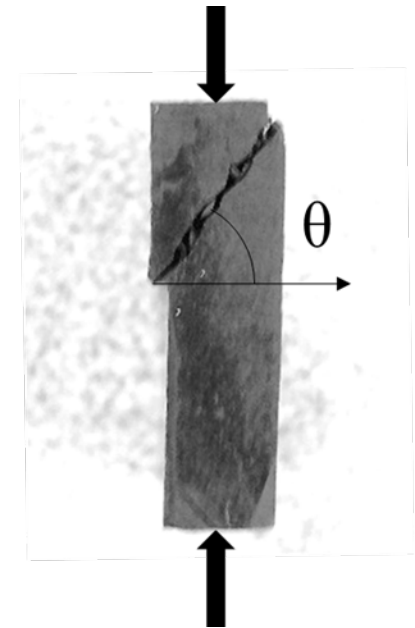

Fracture surface with
fracture angle shown
as θ .

Evaluation of Parameters used in Progressive Damage Models

Starter Crack Tests

- The 0° fracture angle starter cracks failed in tension at back edge of the specimen, similar to specimens with a long notch length (1.875"), which were too long for the specimen geometry.
- 45° fracture angle starter crack specimens had compression damage occur before tensile failure. But this compressive damage had a large crack jump (instantaneous crack propagation) similar to crack initiation from a blunt crack tip (notch tip).
- Baseline specimens (no starter crack) were all successful in matrix compression damage initiation and propagation.
- Result: Starter cracks were unable to aid matrix compression propagation

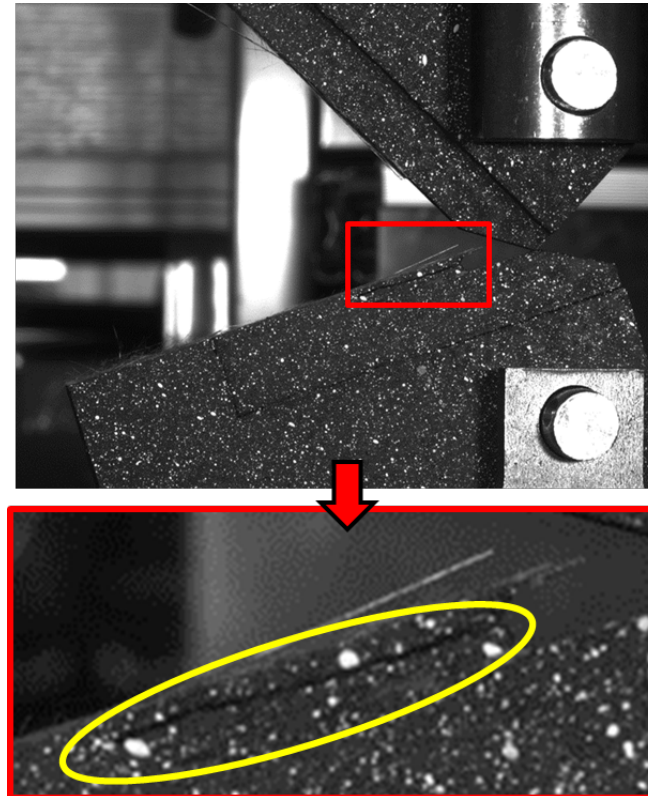

0° Starter Crack Specimen Tensile Failure. (Starter Crack is in red square)

Issues With Starter Cracks

- The reason starter cracks do not work with matrix compression is due to complex fracture surface produced from compression loading. A compressive fracture surface creates a "V" or "W" shape unlike tension damage which creates a straight (0° fracture surface) through the thickness of the specimen (Crack Surfaces shown below).



B



C

B: "V" fracture surface that occurs with a compression crack.

C: "W" fracture surface that occurs with a compression crack.

Linear Unloading Assumption

Linear Loading Assumption:

To understand if a linear unloading assumption was valid the following analysis was preformed.

- After tests were complete, load-displacement data was isolated into separate loading and unloading data sets to check if unloading can be assumed linear using MATLAB's Curve fitting tool.
- The separated unloading data was then curve fit to a linear equation (mx+b).
- Curve fit data showed that it is valid to assume that the unloading line is linear as it has a R² High: 0.995224 , Low: 0.966167.

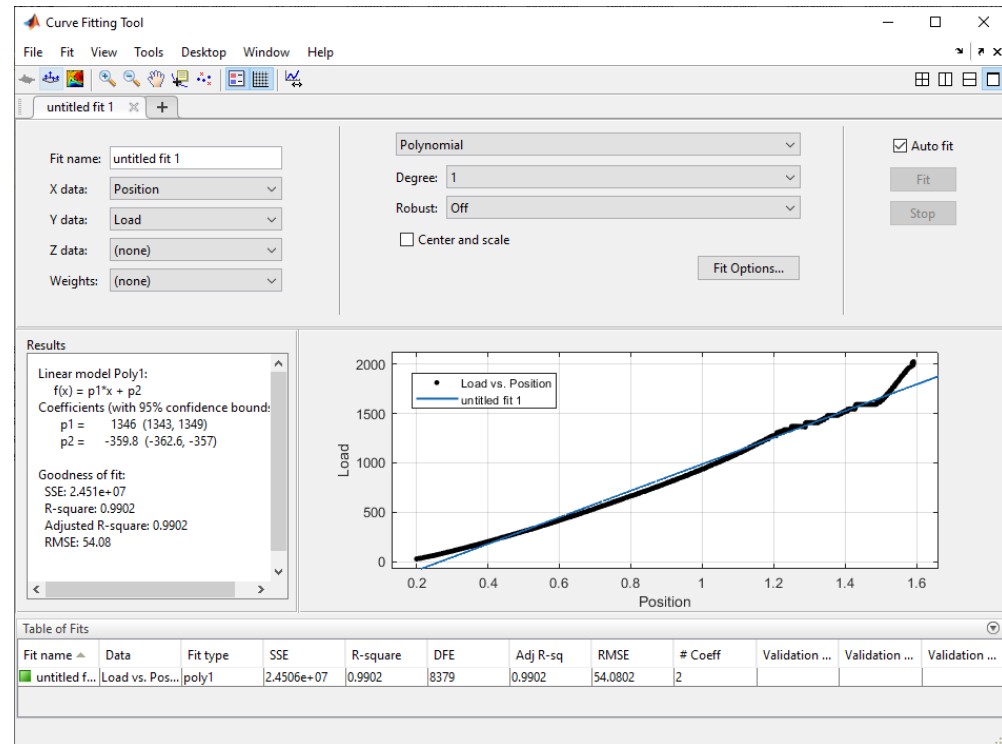

LEFM Applicability

- Using the mass manufacturing methods, experiments were conducted using various notch length to determine if matrix compression follows Linear Elastic Fracture Mechanics with the commercially-available material.
- The specimens exhibited a decrease in peak load as the notch length was increased.
- The log-log plot of the data on the right follows a linear trend with an R^2 value of 0.83, and a slope of (-0.54 ± 0.22) .
- The matrix in compression has been experimentally shown to follow the laws of LEFM.

