The logo for the Joint Advanced Materials and Structures Center of Excellence (JAMS) is displayed at the top center. It consists of the letters 'JAMS' in a bold, blue, textured font. Below the text are two curved, brush-stroke-like lines: a yellow one on top and a dark blue one on the bottom, both curving from left to right.

# JAMS

## **Aging of Composite Aircraft Structures Beechcraft Starship and B-737 Horizontal Stabilizer**

**John Tomblin, PhD**  
*Executive Director, NIAR*

**Lamia Salah**  
*Sr. Research Engineer, NIAR*



June 17<sup>th</sup>, 2008

**The Joint Advanced Materials and Structures Center of Excellence**

# FAA Sponsored Project Information

- Principal Investigators & Researchers
  - Dr. John Tomblin, Wichita State University
  - Lamia Salah, Wichita State University
- FAA Technical Monitor
  - Curtis Davies
- Other FAA Personnel Involved
  - Larry Ilcewicz, Peter Shepyrkevich
- Industry Participation
  - Mike Mott, Ric Abbott

Wichita State University

- **Current market/ economic conditions are requiring the use of aircraft structures beyond their DSO**
- **Industry is relying on existing inspection standards to ensure aging aircraft airworthiness**
- **Most aging studies are focused on metallic structures, need to address composite aging as well**
- **To evaluate the aging effects on a Beechcraft starship (NC-8) main wing after 12 years of service (1827 hours)**



- Program was launched in 1982
- Objectives were to produce the most advanced turboprop business airplane feasible at the time and to promote the use of composites in a business aircraft
- Benefits: to achieve elaborate contours through composite molding, lower part count, manufacturing simplicity, composite's resistance to corrosion, good fatigue properties, weight savings.
- 70% of the airframe by weight is composite
- FAA certification was obtained on June 14<sup>th</sup> 1988 to FAA part 23 regulations and special conditions
- A total of 53 airframes were built but only a handful ever sold. In 2003, the OEM decided to retire the entire Starship fleet except five that were still flying as of Summer of 2007.

- **Non-Destructive Inspection to identify flaws induced during manufacture/ service (delamination, disbonds, impact damage, moisture ingress, etc...)**
- **Coupon level static and fatigue tests to investigate any degradation in the mechanical properties of the material (comparison with OEM tests)**
- **Physical and thermal tests to validate design properties, identify possible changes in the chemical/ physical/ thermal properties of the material**
- **Full scale static, durability and damage tolerance tests to evaluate the structural health/performance of the main wing 19 years since manufacture (12 years in service)**

# Test Article Description (Main Wing)

- Monocoque structure with three spars and five full-chord ribs symmetric wrt about the aircraft centerline
- The wing skins are cured in one piece 54 feet tip to tip
- The wing skins are secondarily bonded to the spars and ribs using paste adhesive

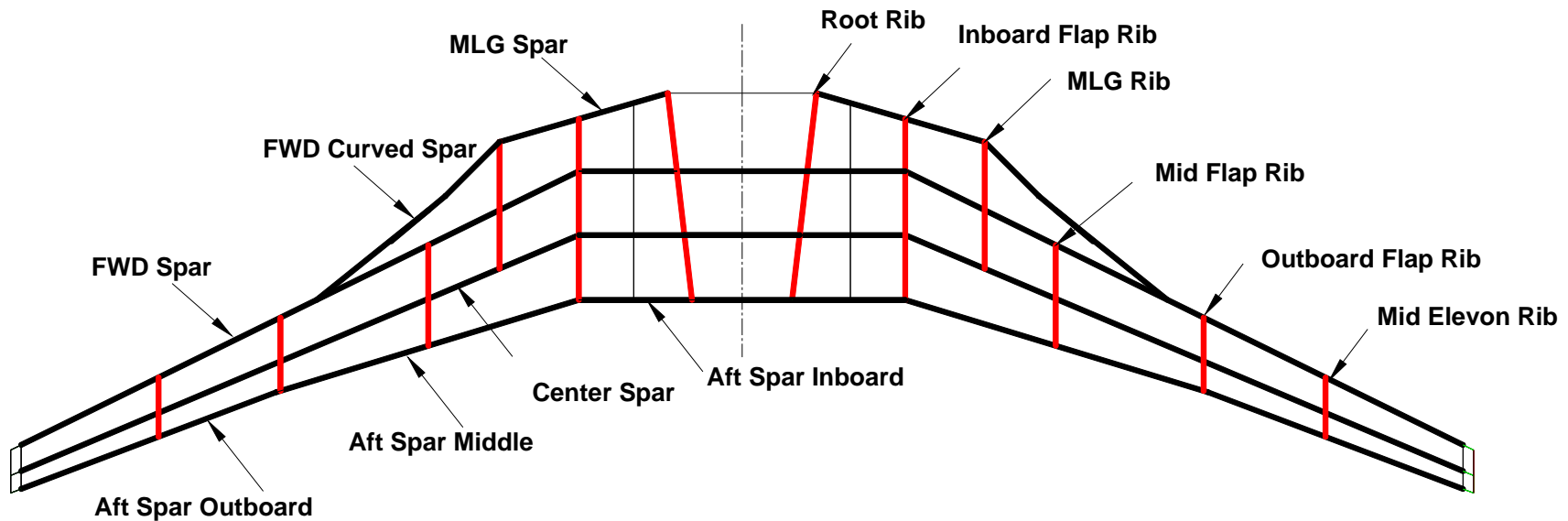

Wichita State University

# Test Article Description (Main Wing)

- **H-Joint:** used to join the upper and lower skins to the spars
- A cutout is first routed in the skin prior to bonding the joint to the skin.
- The joint is then secondarily bonded to the skin using paste and film adhesive
- The spars are finally bonded to the assembly using paste adhesive

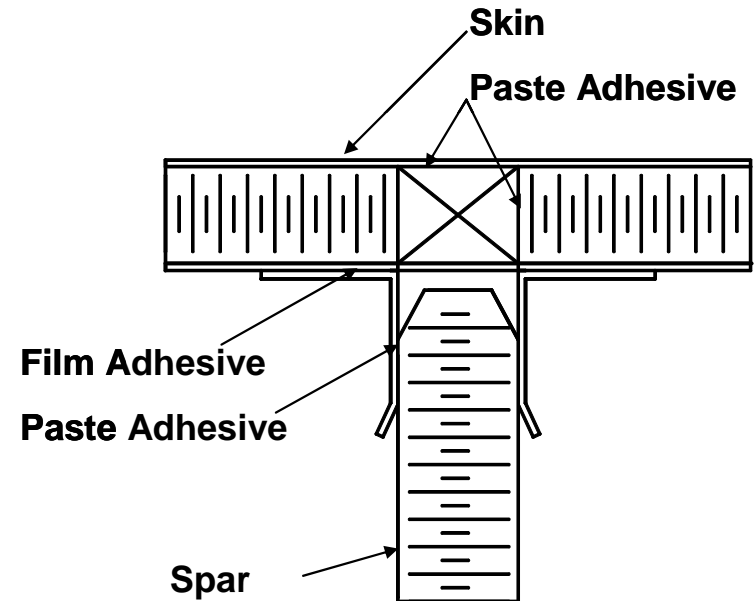

H-Joint Cross Section

BL 199 US



Wichita State University

# Test Article Description (Main Wing)

- **V-Joint:** used to bond the upper and lower wing skins to sections of the forward and aft spars
- The pre-cured graphite epoxy joint is secondarily bonded to the wing skin first using paste adhesive
- After this process is completed, the assembly is subsequently joined to the spars using paste adhesive

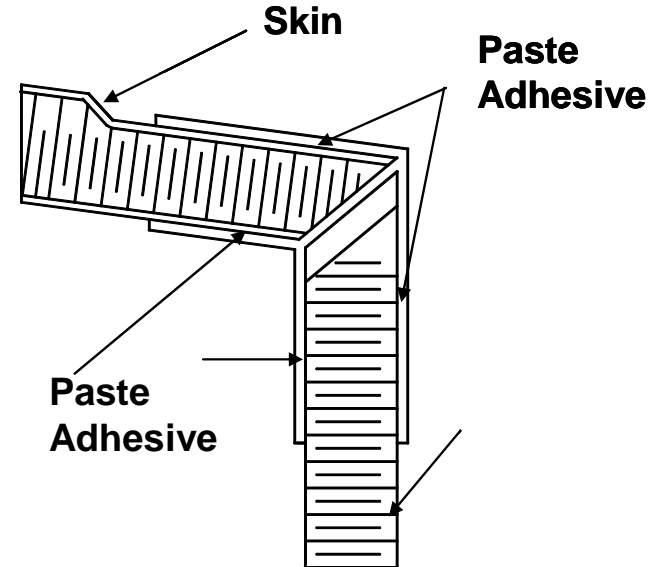

**BL 78 LS**

Wichita State University



# Test Article Description (Main Wing)

- **Lightning Protection achieved through the use of hybrid woven graphite/ aluminum fabric as the surface ply in all exterior surfaces**
- **Materials used was E7K8 12K/ 280 and 145 tape and AS4 E7K8 3K/195 PW fabric. Material qualification was conducted per Military Handbook 17 specifications.**
- **Lamina and Laminate testing was conducted to generate tension, compression, shear strength and strain allowables in various environmental conditions**

- Main components disassembled (fuselage, forward wing, main wing, nacelles, fuel tanks)
- Main wing cut in two pieces for ease of transportation

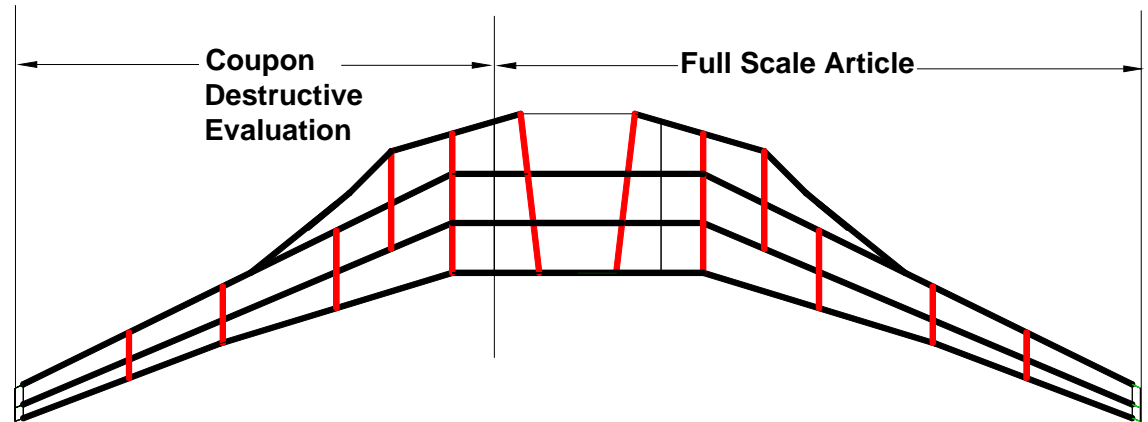
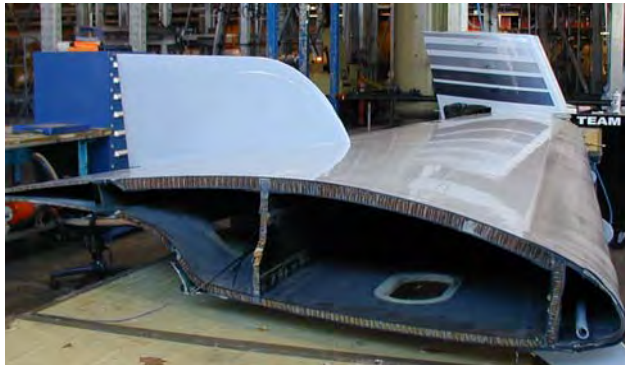

Preliminary TTU Non-Destructive inspection showed no evidence of flaws induced during manufacture or service in the skins. OEM records suggest that porosity levels in the upper skin LE flanges exceed 2.5%

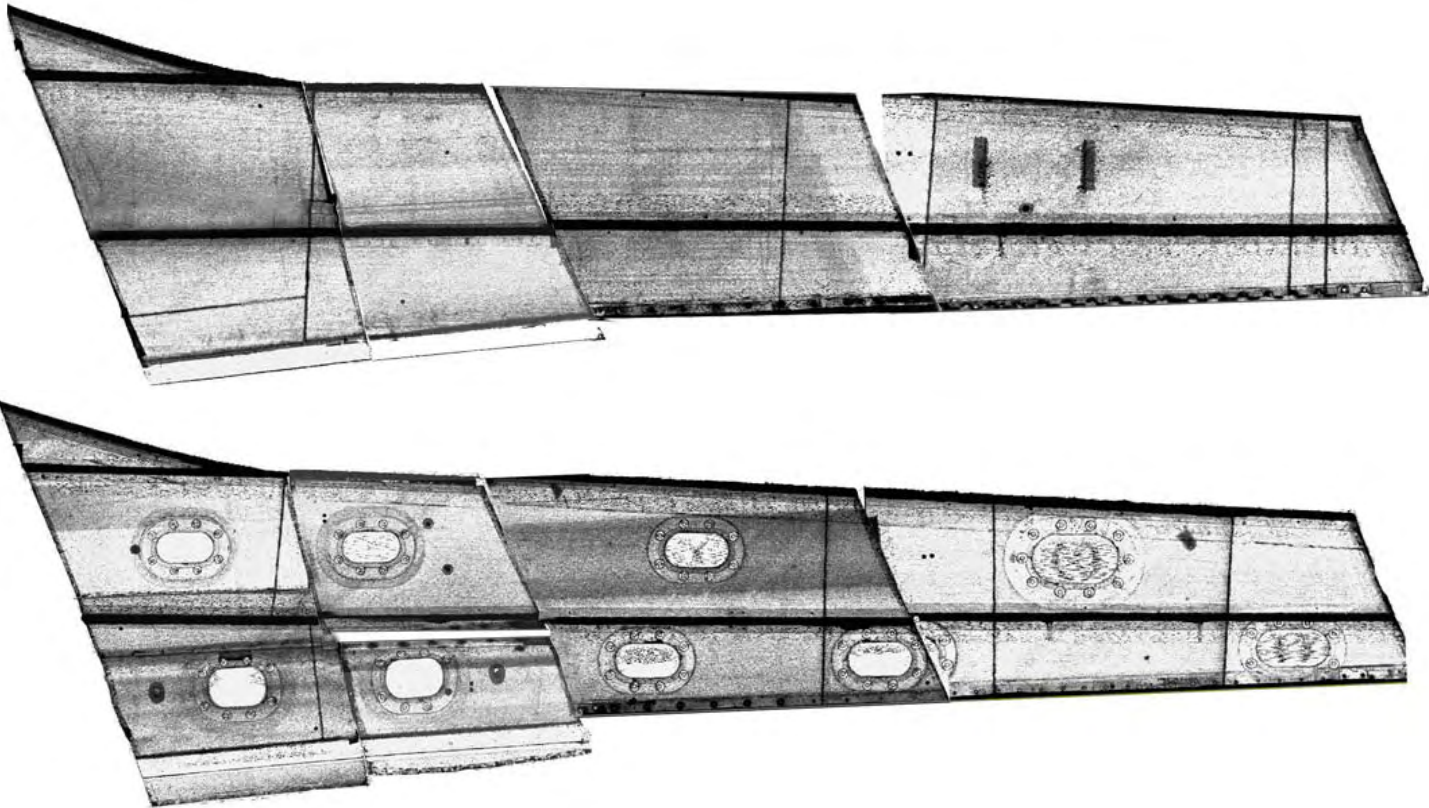

- **Storage Modulus** is an indication of the stiffness of the material,  $\tan\delta$  is a measure of the damping of the material
- **DMA curves** with a shallow storage modulus transition and a narrow  $\tan\delta$  indicate a highly cross linked material

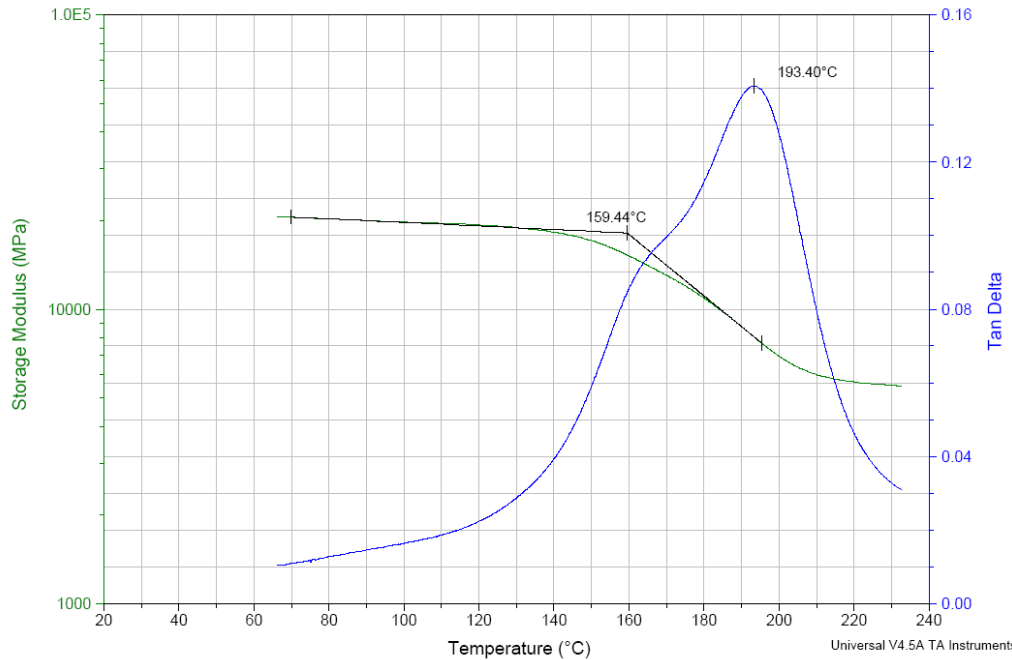

**Lower Skin LF BL 260 DMA results**  
**Storage Modulus 159°C 318°F**  
**Tan  $\delta$  193°C 379°F**

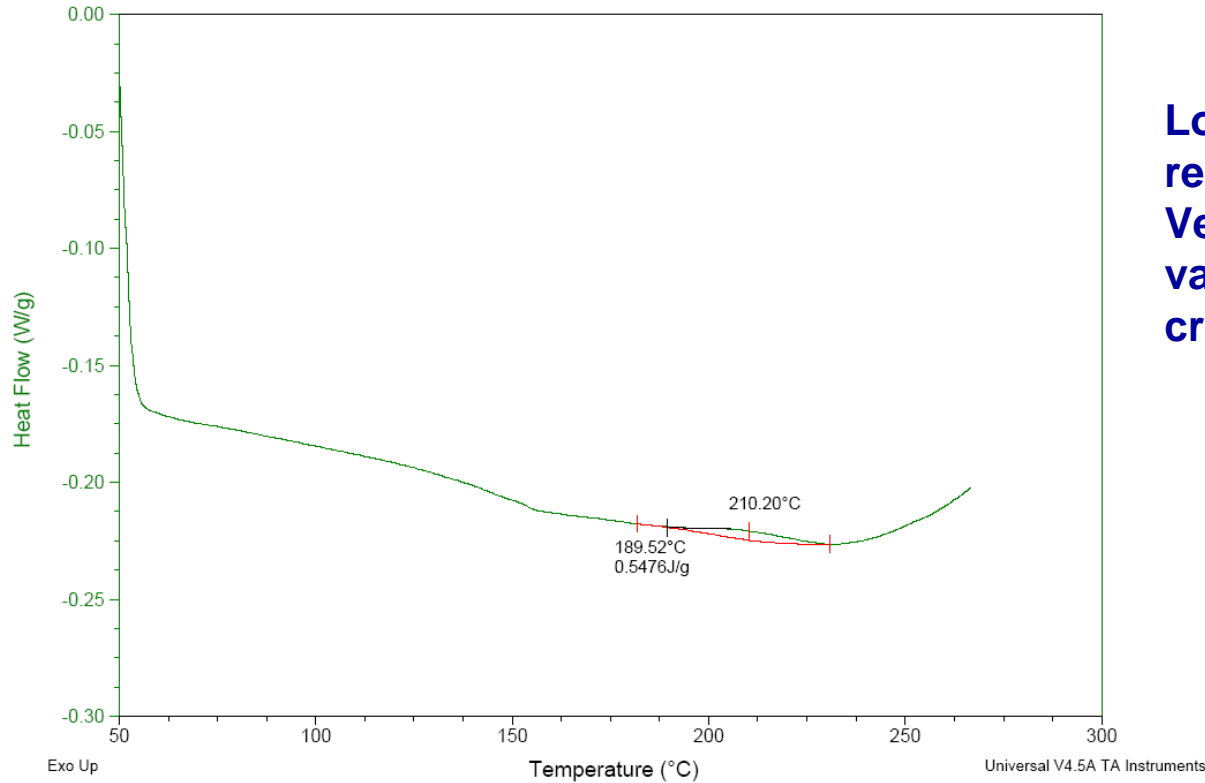

**Lower Skin UF BL 260 DSC results**  
**Very small heat of reaction values indicative of a highly cross linked material**

# Full Scale Structural Test

- A baseline Non-Destructive Inspection scan has been generated prior to conducting the full scale test in order to identify possible manufacturing flaws or defects induced during service
- NDI grid has been drawn on the structure for ease of inspection and flaw growth monitoring
- Visual inspection, TTU and tap testing were used for the inspection
- A few areas in both the upper and lower skins have been identified as disbonds by the inspectors

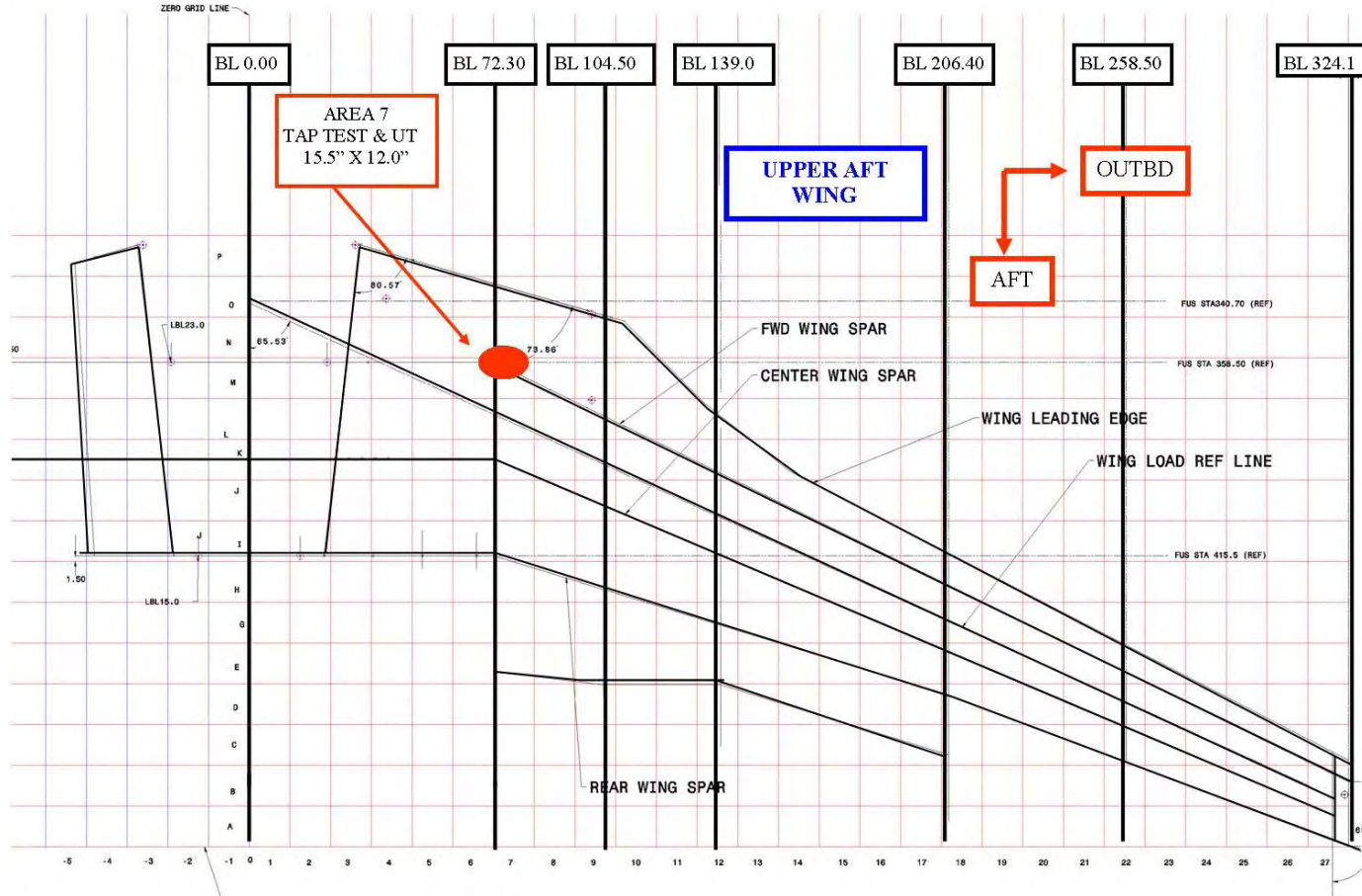

Wichita State University

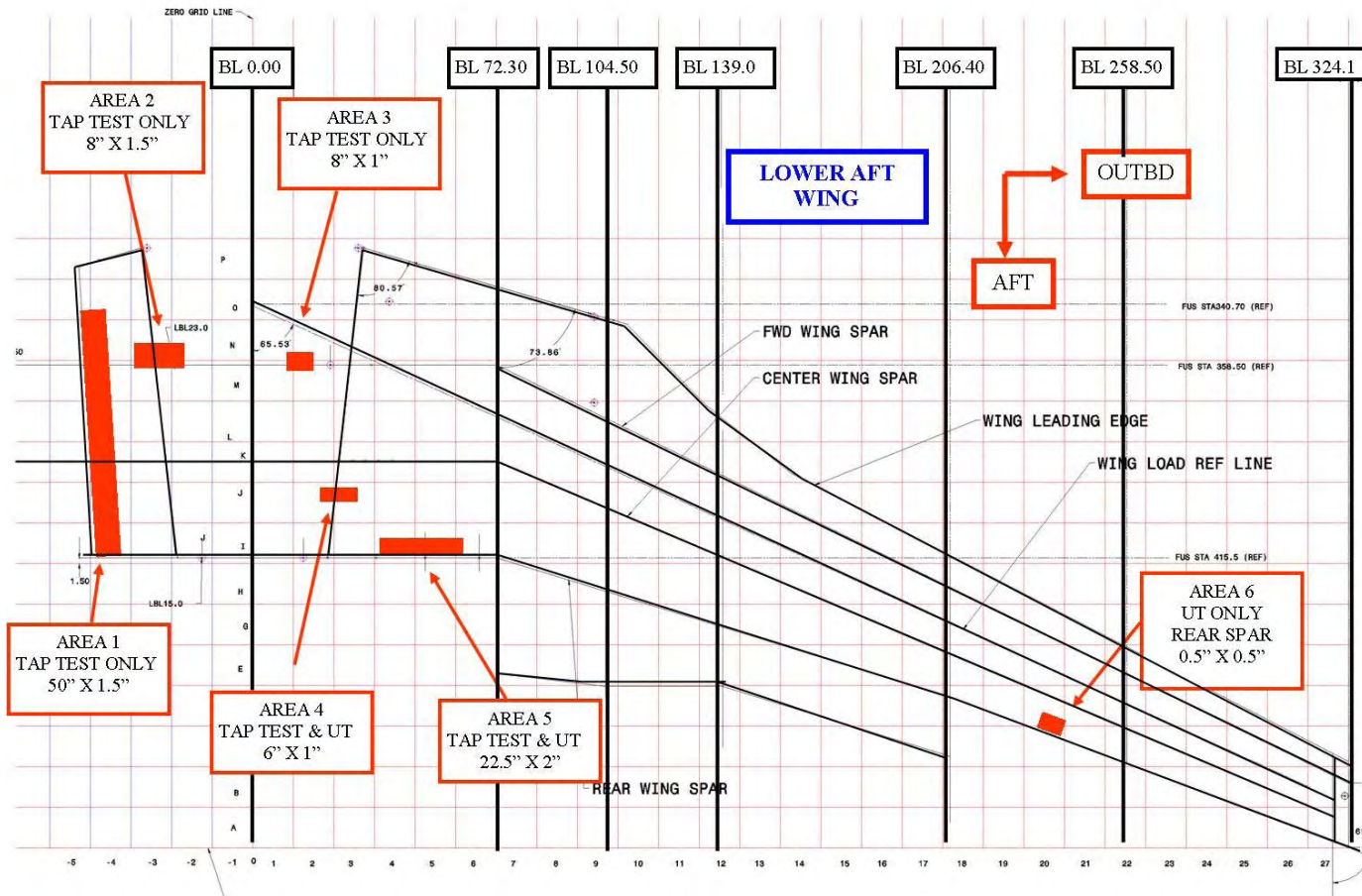

Wichita State University



- Wet lay-up repair per BS 24204 and BS23727 using EA 956 resin
- Repair Analysis conducted by the OEM and demonstrated positive margins for axial loading
- Repair Stacking sequence: PW45/T0/8HS0/T0/8HS90/T0/PW45



**Scarf repair area**



**Ply 1 application**

Wichita State University

# Wet Lay-Up Repair



**Ply 2 application**



**Cured Repair**

Wichita State University

# Strain Gage Identification/ NDI Inspection Grid

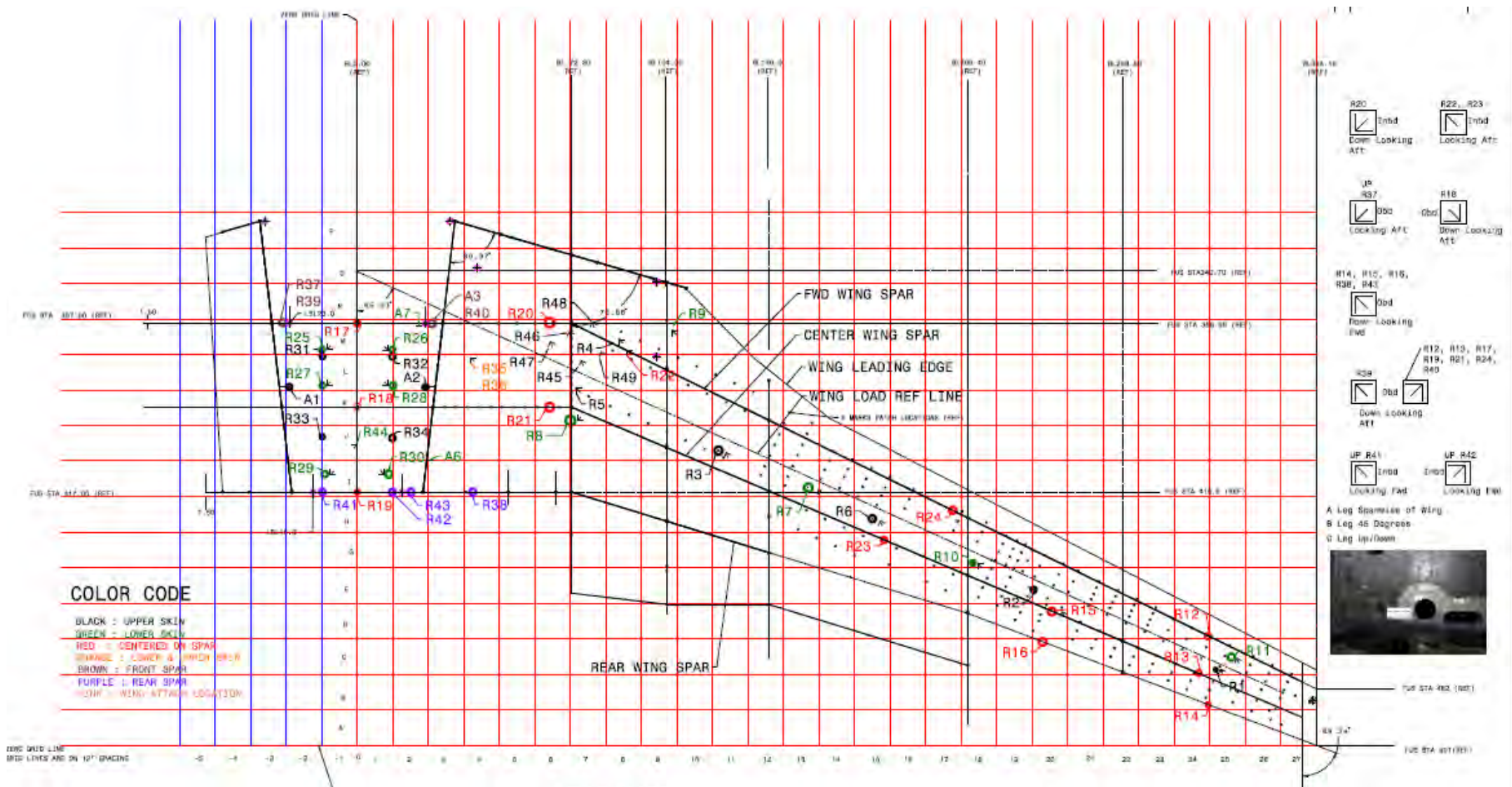

Wichita State University



Repair Instrumentation

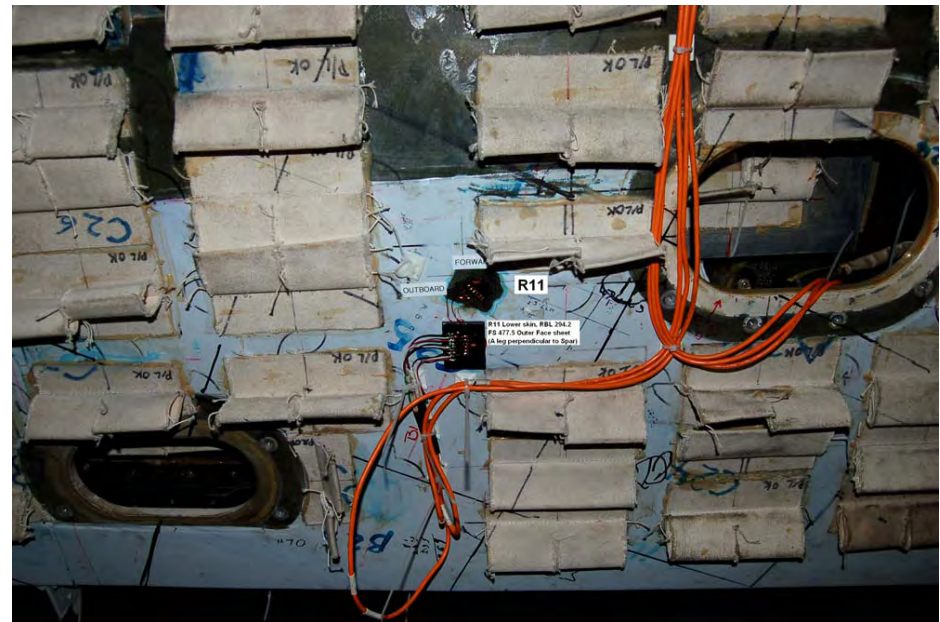

SG R11 Lower Skin RBL 294.2 FS 477.5

# Limit Load Test- Upbending Case Cond 4A

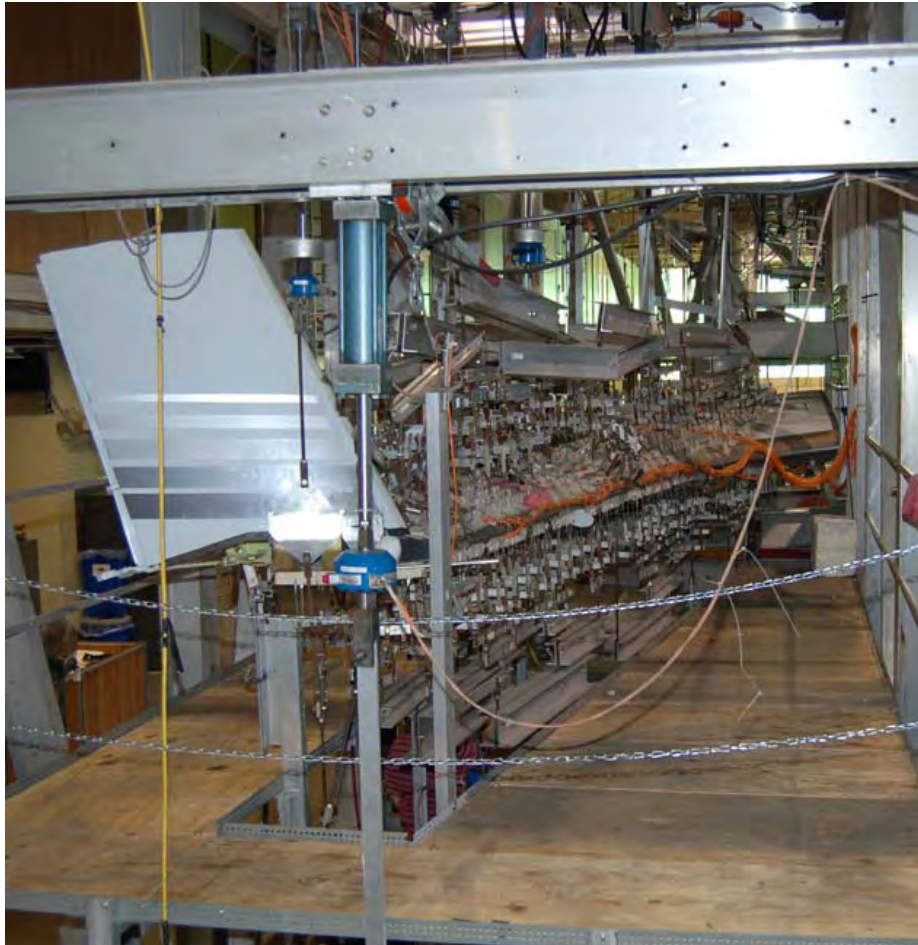

- Limit Load Cond 4A- (Max Positive Moment)
- During certification, wing suffered damage at 122%LL, 135%LL and 141%LL before sustaining UL
- Shear/ moment/ torque introduced matched the static 4A values from RBL 100 to RBL 360

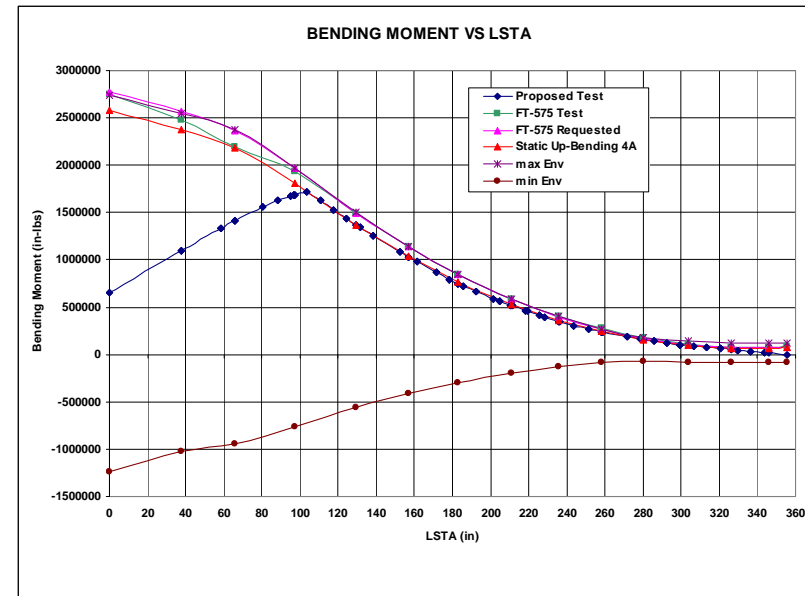

Wichita State University

# Limit Load Test

- Wing sustained 100% Up-bending Limit Load Test



Wichita State University

- Strain vs % LL comparison between current test and wing max upbending certification test (Cond 4A)
- No major change in compliance, certification data correlates very well with aged structure limit load test results

**Strain vs % LL (Current Test vs Static Max Up-Bending Test to failure)**

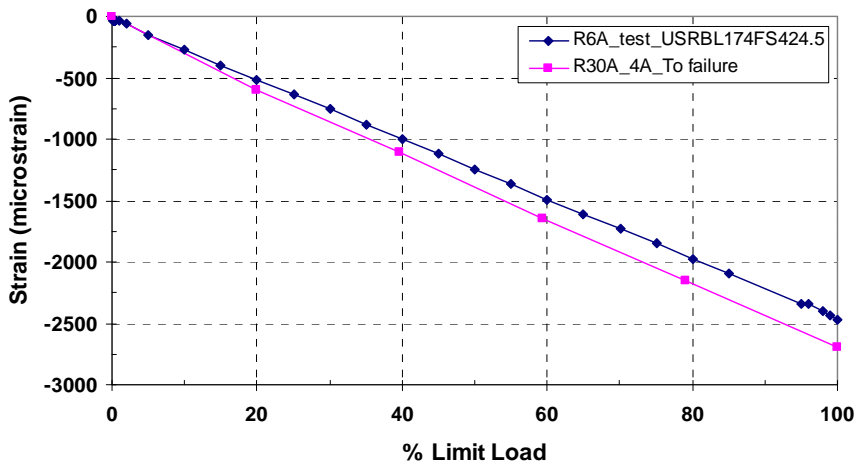

**Strain vs % LL (Current Test vs Static Max Up-Bending Test to failure)**

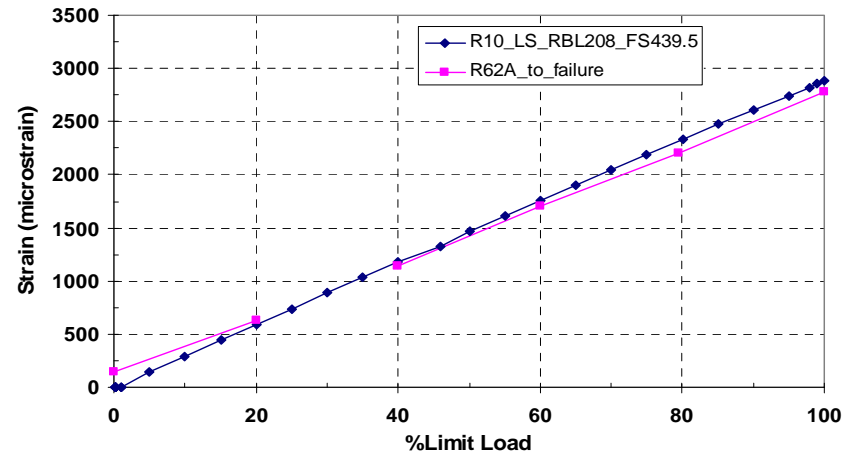

- Image Analysis and physical tests
- Mechanical Testing: flatwise tension C297, flexure C393, core shear C273

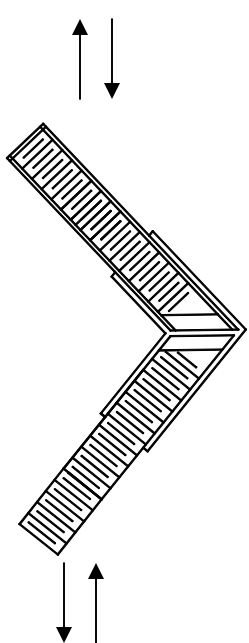

**V-joint Static/ Cyclic  
Tension/ Compression**

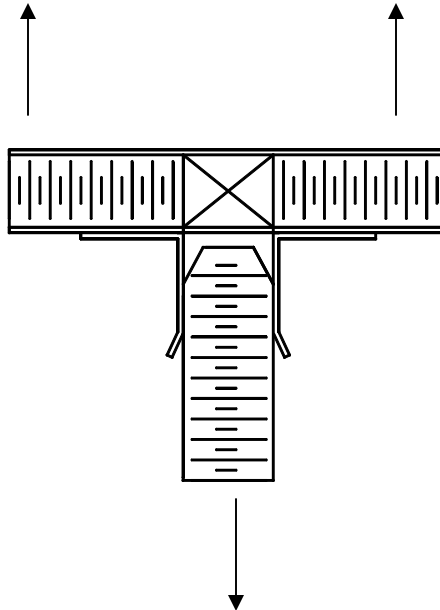

**H-joint Static/ Cyclic  
Tension**



**FHT**

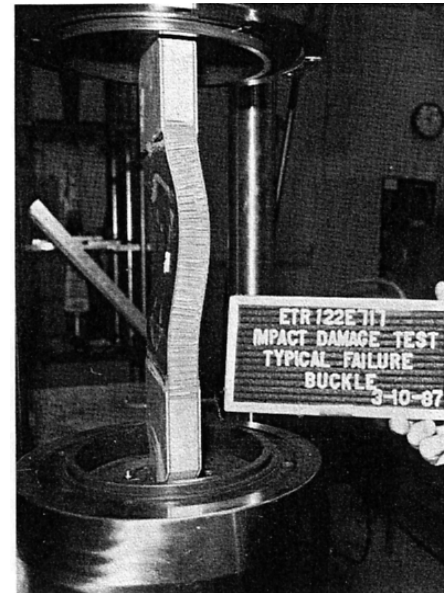

**Compression  
after impact**

Wichita State University



- **Structure held extremely well after 12 years of service: no obvious signs of aging to the naked eye as would a metal structure with a similar service history exhibit**
- **Preliminary Thermal analysis results show no degradation in thermal properties of the material and that the skins are fully cured/ cross-linked**
- **LH NDI showed no major defects/ damage in the skins introduced during manufacture or service**
- **NDI response subject to operator interpretation (full test article inspection)**
- **Full scale test results of the “aged wing” correlated very well with the results obtained for the certification article**

# B737-Stabilizer FAA Sponsored Project Information

- Principal Investigators & Researchers
  - Dr. John Tomblin
  - Lamia Salah
- FAA Technical Monitor
  - Curtis Davies
- Other FAA Personnel Involved
  - Larry Ilcewiz
- Industry Participation
  - Dr. Matthew Miller, The Boeing Company
  - Dan Hoffman, Jeff Kollgaard, Karl Nelson, The Boeing Company

To evaluate the aging effects of a (RH) graphite-epoxy horizontal stabilizer after 18 years of service (48000 flights, 2/3 of DSO)

- Non-Destructive Inspection to identify flaws induced during manufacture or service
- Mechanical testing on coupons extracted from the structure to investigate any degradation in the mechanical properties of the material
- Physical, thermal and image analysis to quantify porosity and moisture levels in the structure, characterize its thermal properties and its state at the micro-structural level (microcracks, etc...)



Wichita State University

- The B737-200 CRFP stabilizer was built as part of the NASA ACEE (Aircraft Energy Efficiency) program initiated in late 1975
- The purpose was to develop new technologies to reduce fuel consumption in aircraft structures
- The ACEE program was subdivided into four development areas: laminar flow systems, advanced aerodynamics, flight controls and composite structures
- The ACEE Composites program focused on redesigning existing structural components using lighter materials
- A building block approach was followed where composite structure development would start with lightly loaded secondary components followed by medium primary components and finally wing and fuselage development



# Background

- The OEM redesigned, manufactured, certified, & deployed five shipsets of 737-200 horizontal stabilizers using graphite-epoxy composites
- Certification was achieved in 1982 and all shipsets were introduced into commercial service in 1984
- The OEM closely monitored the performance of the stabilizers for 7 years. Outstanding performance was demonstrated with no in-service incidents attributed to aging of the composite structure

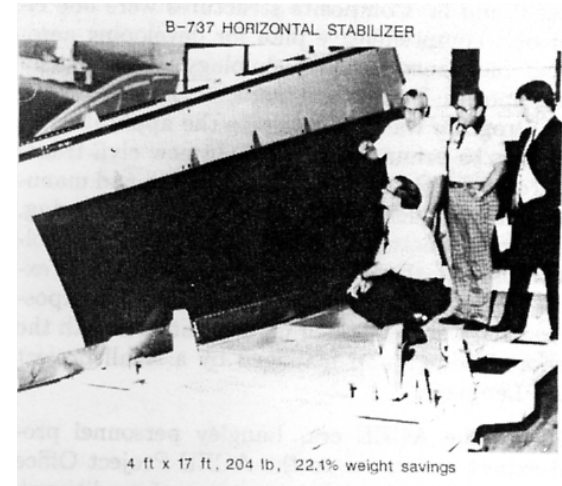

Wichita State University

# Boeing 737 Fleet Status



- DSO of 75000 flights
- Upper Skin Inboard delaminations at stringer runouts due to maintenance personnel walking on a no-step zone

Shipset / Production Line #	Entry into Service	Carrier	Status as of January 1, 2008
1 / 1003	2 May 1984	A & E	(60000 hours, 45000 flights)
2 / 1012	21 March 1984	A	Removed from Service (62000 hours, 47000 flights)
3 / 1025	11 May 1984	B	Damaged beyond repair 1990; partial teardown completed in 1991 (17300 hours, 19300 flights)
4 / 1036	17 July 1984	B & C	Stabilizers removed from service 2002 (approx. 39000 hours, 55000 flights); partial teardown of R/H unit at Boeing
5 / 1042	14 August 1984	B & D	Stabilizers removed from service 2002 (approx. 52000 hours, 48000 flights); teardown of L/H unit at Boeing; teardown of R/H unit at NIAR, Wichita State

Wichita State University

# Horizontal Stabilizer Description

- Designed such that it is interchangeable with the metal structure in terms of geometry, aerodynamic shape to meet control effectiveness and flutter requirements
- 21.6% weight savings/ metal structure
- Material: NARMCO T300/5208
- Stiffened skin structural box arrangement with co-cured I stiffeners
- Honeycomb ribs for cost efficiency, fastened to the skins using shear ties
- Spars are I beams consisting of two pre-cured C channels and two pre-cured caps subsequently bonded together
- Root lugs used steel plates bonded and bolted to a pre-cured graphite epoxy chord

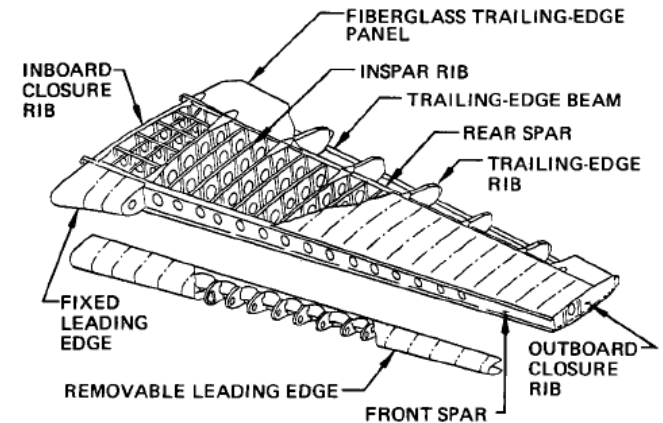
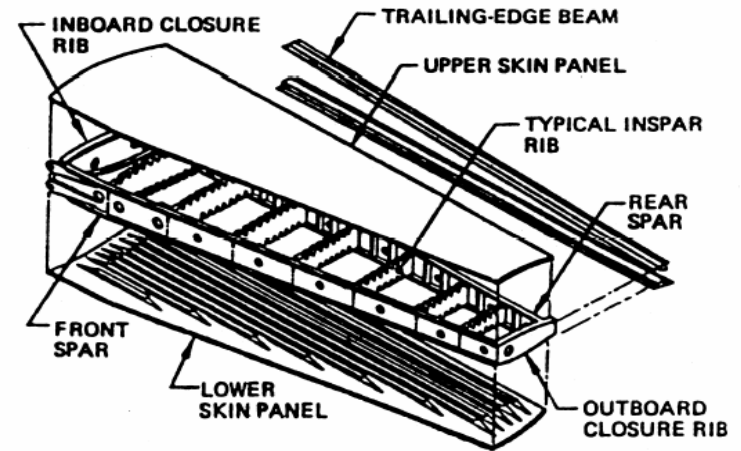

**Composite vs. Metal Stabilizer**

## Corrosion Protection Scheme

- Corrosion protection by co-curing a fiberglass ply onto the graphite-epoxy structure or painting the surface with primer and epoxy enamel
- All aluminum structure was anodized or alodine treated, primed and enameled
- Fasteners were installed with wet polysulfide sealant

## Lightning Protection Scheme

- Lightning protection scheme provided an electrical path around the perimeter of the structure. Bonding straps were used to connect the aluminum leading edge, the aluminum rib cap of the outboard closure rib, the aluminum elevator spar and the spar lugs
- An Aluminum flame spray was used on the stabilizer's critical strike area. The outboard skin panels were insulated using a layer of fiberglass. Mechanical fasteners were used to electrically connect the aluminum flame area to the metal cap of the outboard closure rib

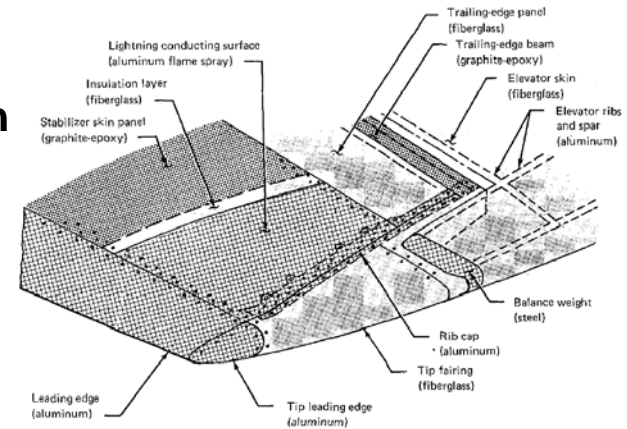



# Disassembly

- Upper skin assembled using Inconel “Big Foot” blind fasteners
- Lower skin assembled using titanium Hi-Lok fasteners with corrosion resistant steel collars and washers
- The upper skin was disassembled first by drilling out the blind fasteners using a Monogram fastener removal kit: the fastener head was drilled out until the shank could be driven out of the structure
- Once the upper skin was dismantled, the lower skin’s Hi-Lok fasteners were disassembled



Wichita State University

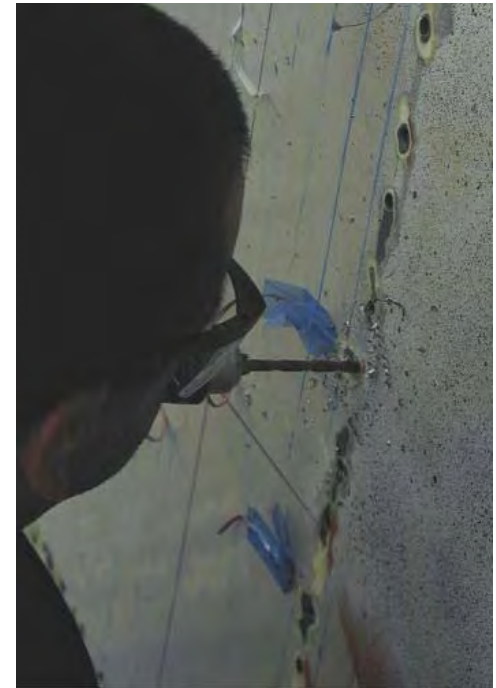

# Disassembly/ Preliminary Findings



**Upper Skin (RH)**

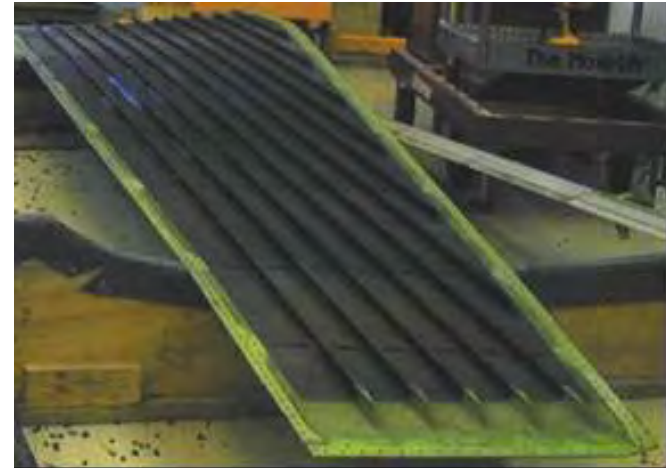

**Lower Skin (RH)**



**Center Box (RH)**

- Structure held very well
- No evidence of pitting or corrosion as would be observed in a metal structure
- No residual strains compared to the LH

Wichita State University

# Disassembly/ Preliminary Findings



**Front (Top) and Rear (Bottom) Spars after disassembly**  
 Wichita State University

# Visual Inspection



Degradation of Tedlar Moisture Barrier film

# Visual Inspection

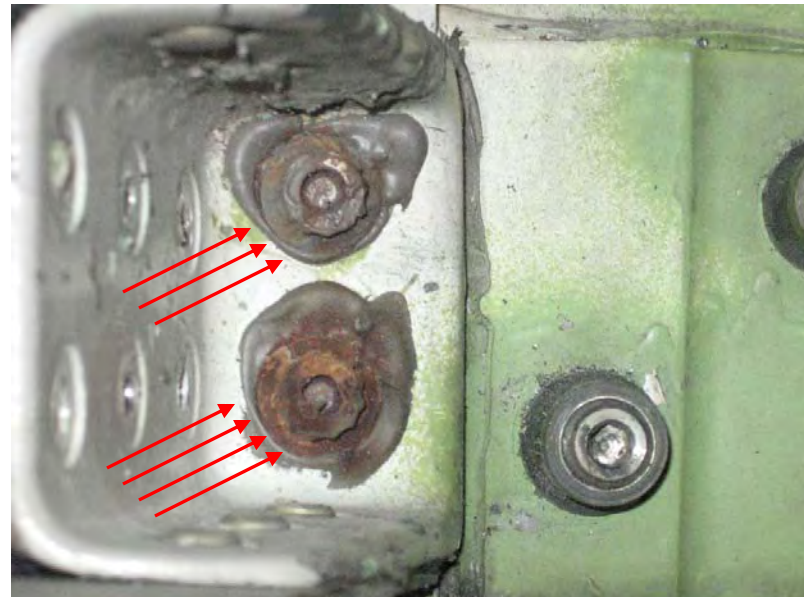
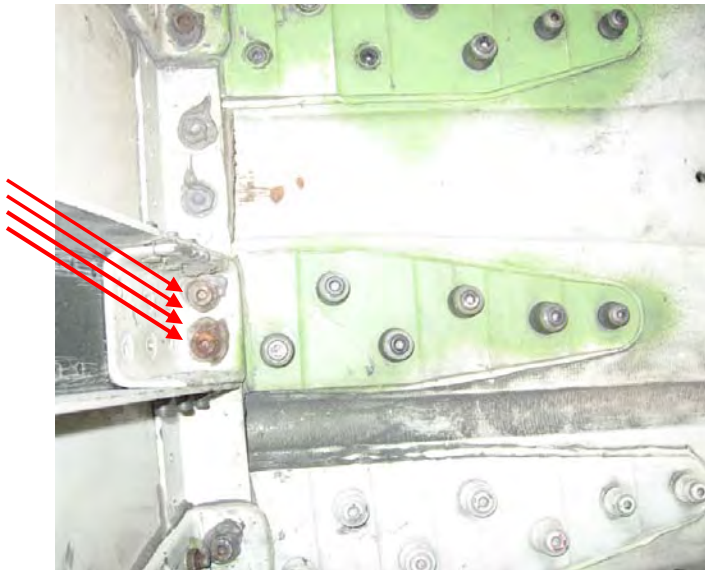

**A few corroded fasteners due to sealant deterioration**

Wichita State University

# Visual Inspection



**Phenolic shims used to fill gaps between skin and ribs**

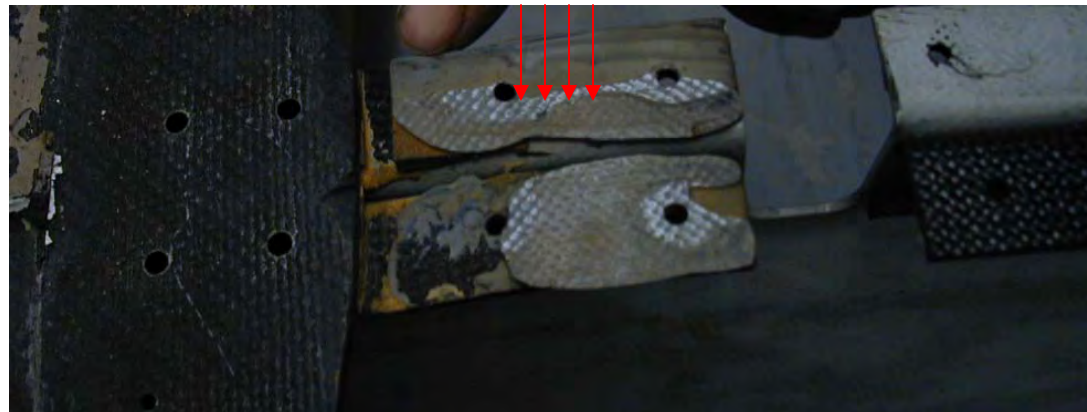

**Liquid Shims used to fill gaps between the upper skin and the stabilizer ribs**

Wichita State University

# Non-Destructive Inspection Prior to teardown

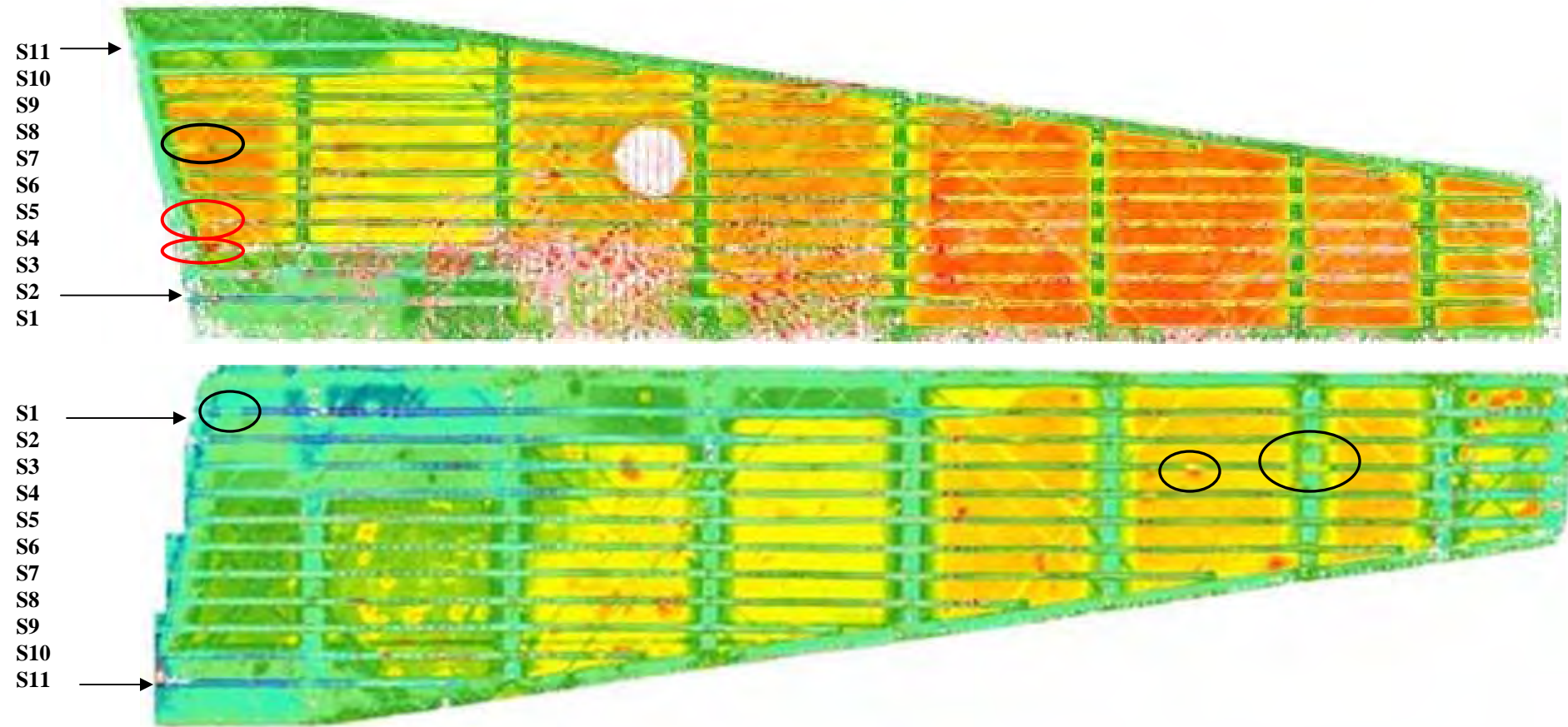

Rapidscan™ analysis (pulse echo time of flight data) of the R/H of the B737 stabilizer  
(Courtesy of Sandia National Laboratories and NDT solutions ltd. UK)  
Wichita State University

# Non-Destructive Inspection after Teardown

- Pulse-echo and through-transmission non-destructive methods were used to inspect the stabilizer using 2.25 Mhz frequency transducers
- Both methods confirmed the large amounts of porosity in the upper skin
- Pulse-echo results obtained confirmed the existence of delaminated stringers and demonstrated the increased accuracy/ sensitivity of the current inspection methods compared to those used in the 1980's

1980's sensitivity



Today's sensitivity

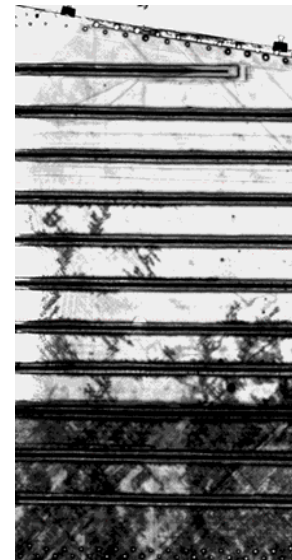

Wichita State University



# Non-Destructive Inspection

- NDI pulse echo inspection showed significant levels of porosity in the upper skin compared to the lower skin (tooling and process variability)
- Porosity levels have been quantified using image analysis/ physical tests
- Very porous repair between rib stations 2 and 3 (str 5 and 8)

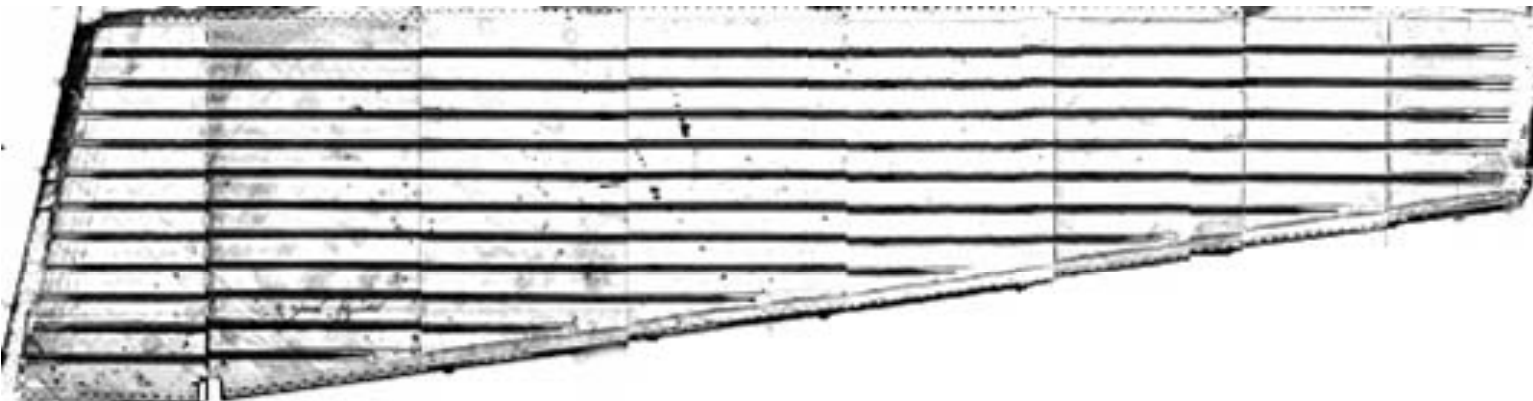

# Non-Destructive Inspection

- Manual Pulse-echo was performed to inspect the skin/ stringer co-cured bonds and identify areas with delaminated stringers



Upper skin Inboard delaminations at stringer runouts

Wichita State University

- Destructive evaluation has been conducted on sections of the stabilizer identified as disbonds from the NDI inspection to verify the existence of these delaminations. Destructive evaluation confirmed the results.

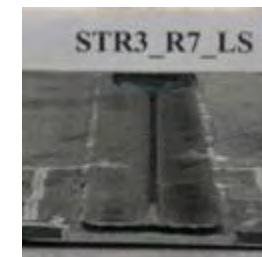
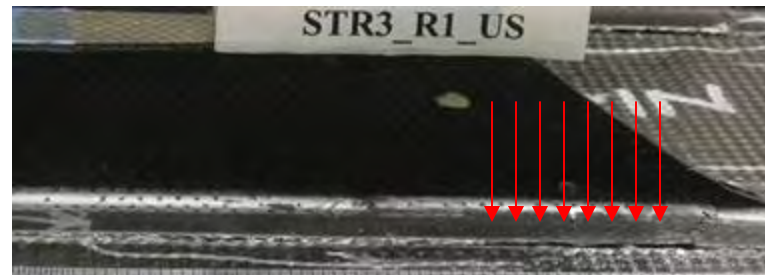
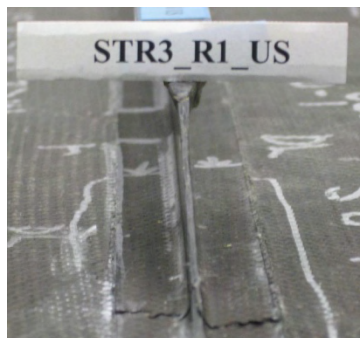
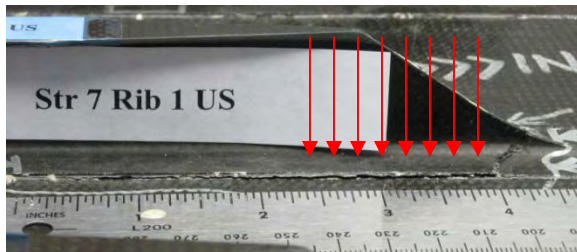

Wichita State University

- Moisture content in the aged structure has been quantified per ASTM D5229: specimens were extracted from different locations in the upper skin and lower skins of the stabilizer and have been dried to evaluate the moisture content of the structure.
- The results showed that the moisture content in the upper skin varied from 0.743 to 0.913% (design moisture level of 1.1%)

Moisture Distribution In the Upper Skin

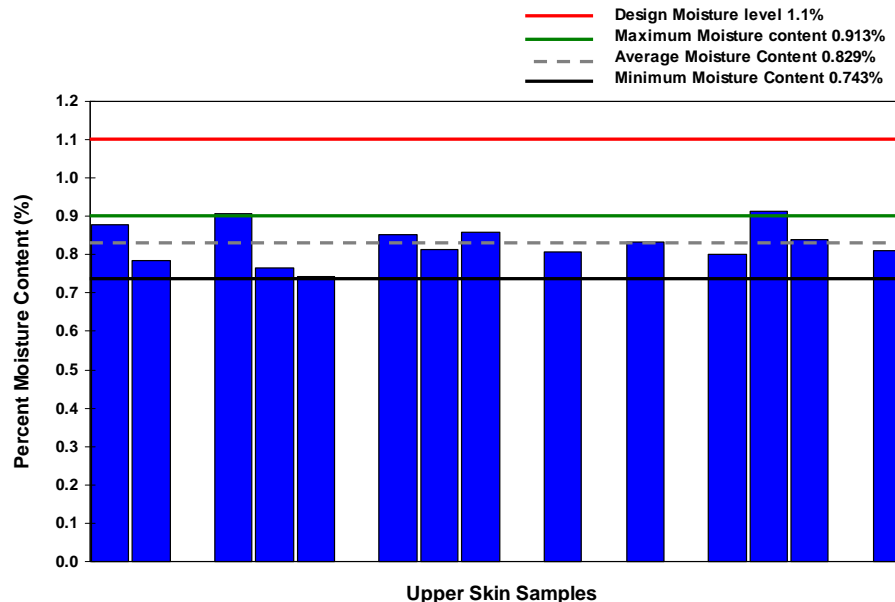

WICNITA STATE UNIVERSITY

Moisture Distribution In the Lower Skin

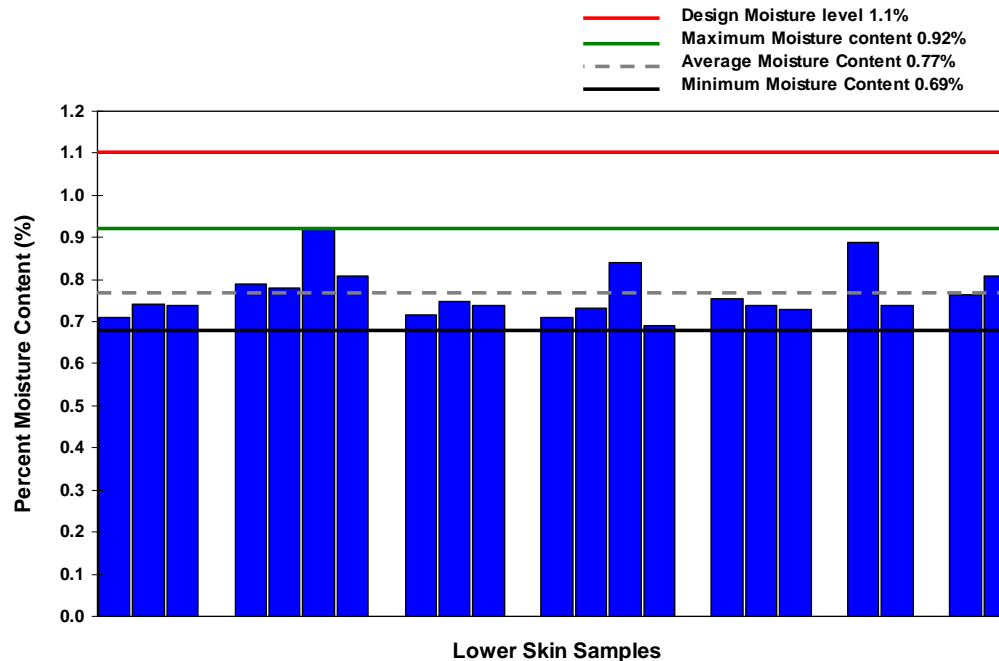

- The moisture content in the lower skin varied from 0.69 to 0.92% (design moisture level of 1.1%)

- Physical tests were conducted per ASTM D3171 to quantify porosity levels in both skins

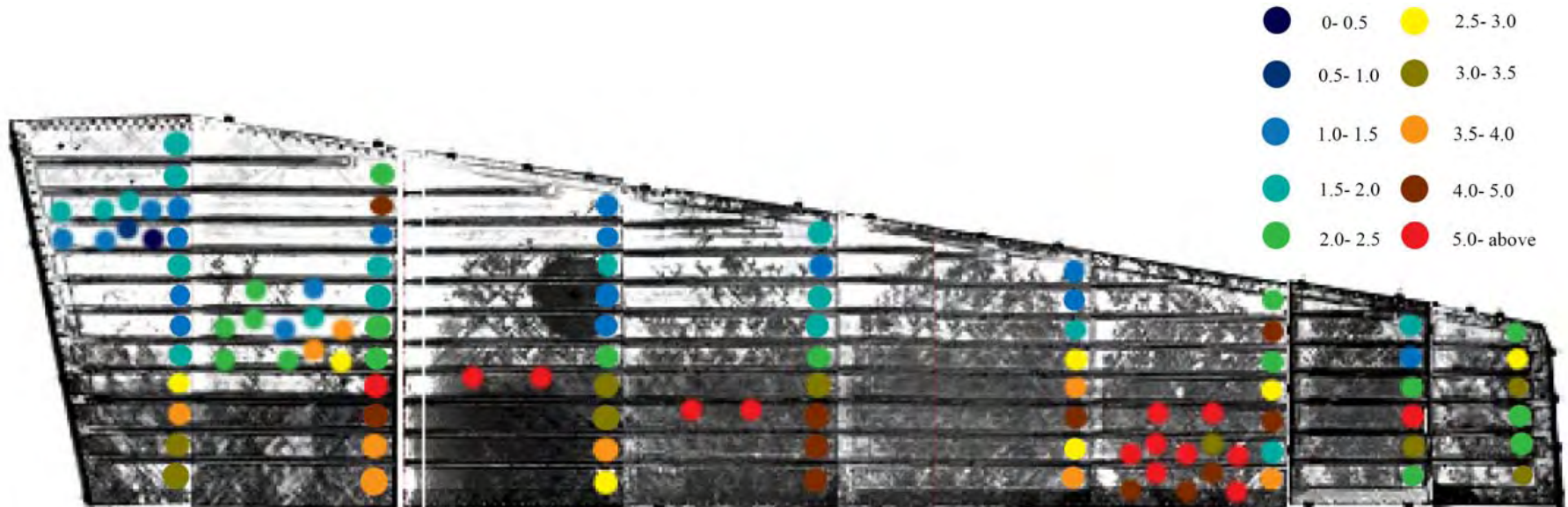

Upper Skin (Max void Content 7.26%)

Wichita State University

- Physical tests were conducted per ASTM D3171 to quantify porosity levels in both skins

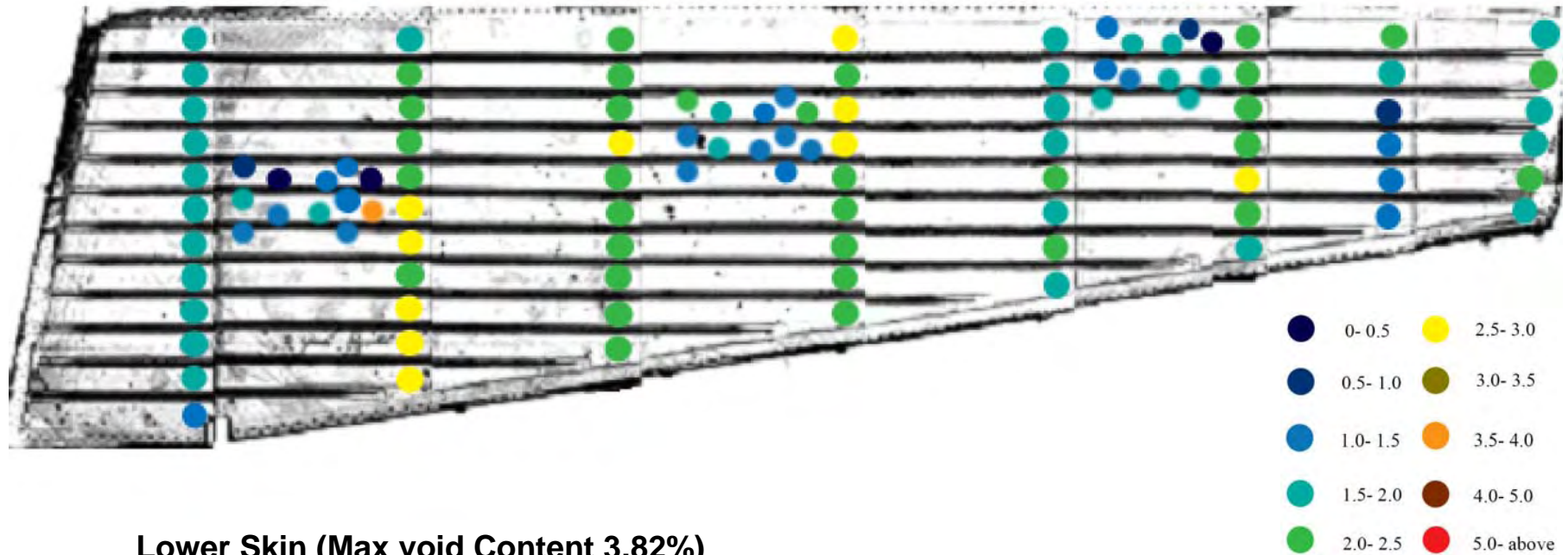

**Lower Skin (Max void Content 3.82%)**

**Front and Rear Spars (Less than 1.14% and 1.67% void content)**

Wichita State University

- DMA technique to determine the glass transition temperature of the aged material for coupons extracted from both the upper and lower skins
- Thermal analysis was conducted on coupons with actual in-service moisture content and dried coupons to compare the difference between the in-service T<sub>g</sub> with respect to the dry T<sub>g</sub>.
- Storage Modulus is an indication of the stiffness of the material, tanδ is a measure of the damping of the material
- DMA curves with a shallow storage modulus transition and a narrow tanδ indicate a highly cross linked material

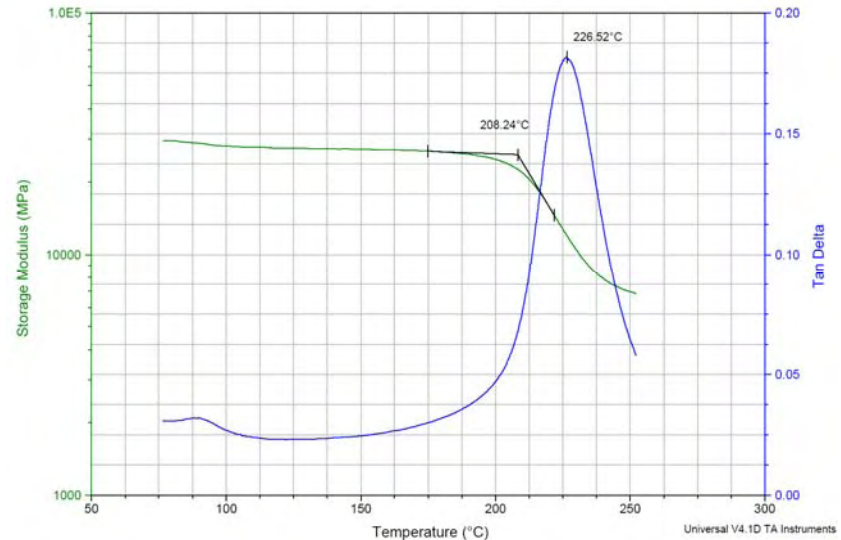
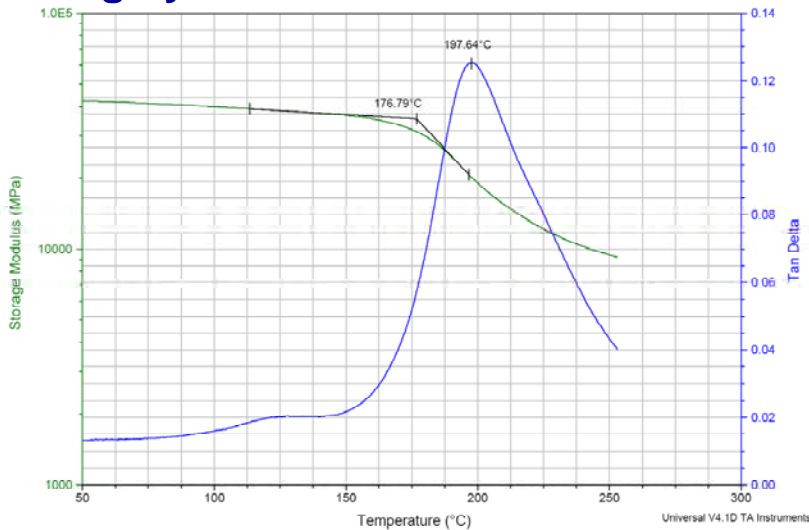



# Thermal Analysis

- Tg values consistent and comparable to LH Results (Courtesy the Boeing Co) average values for RH (201°C/233°C)
- DMA test parameters vary/ Tg obtained is a “wet” Tg (at least 0.69% moisture content)

DMA Results for coupons excised from the upper skin of the B-737 Horizontal Stabilizer (Boeing Method)

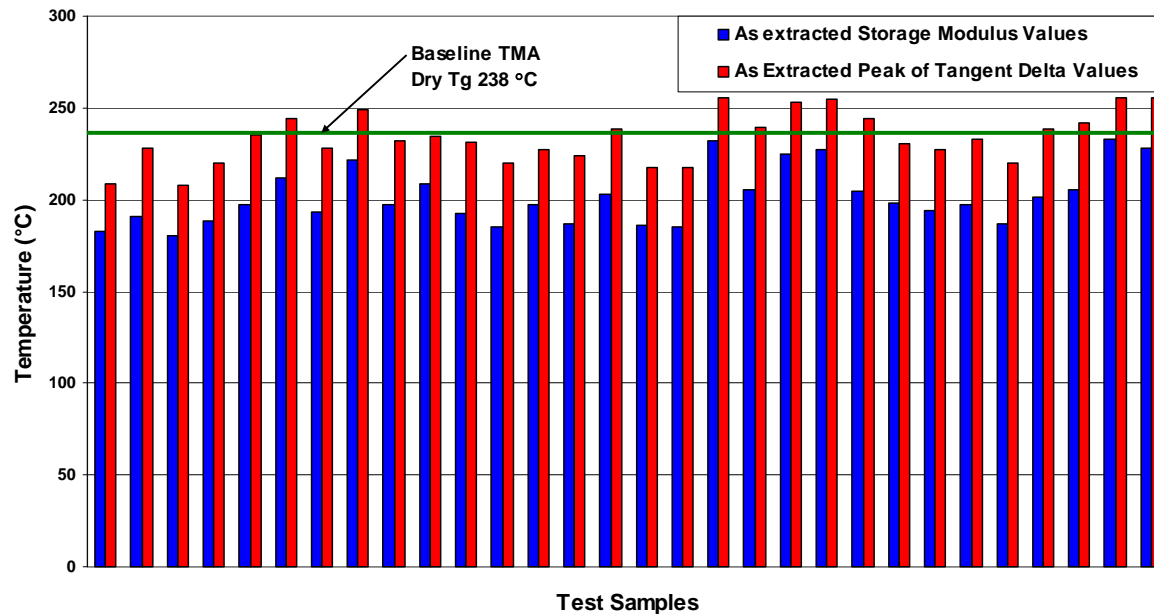

# Thermal Analysis- Spar Skin Comparison

- Spar Tg is about 18°C higher than the skin Tg. (1 cure cycle for skin, 2 for spars)

DMA Results Comparison for coupons excised from the upper skin and the front and rear spars of the B-737 Horizontal Stabilizer (ASTM Standard)

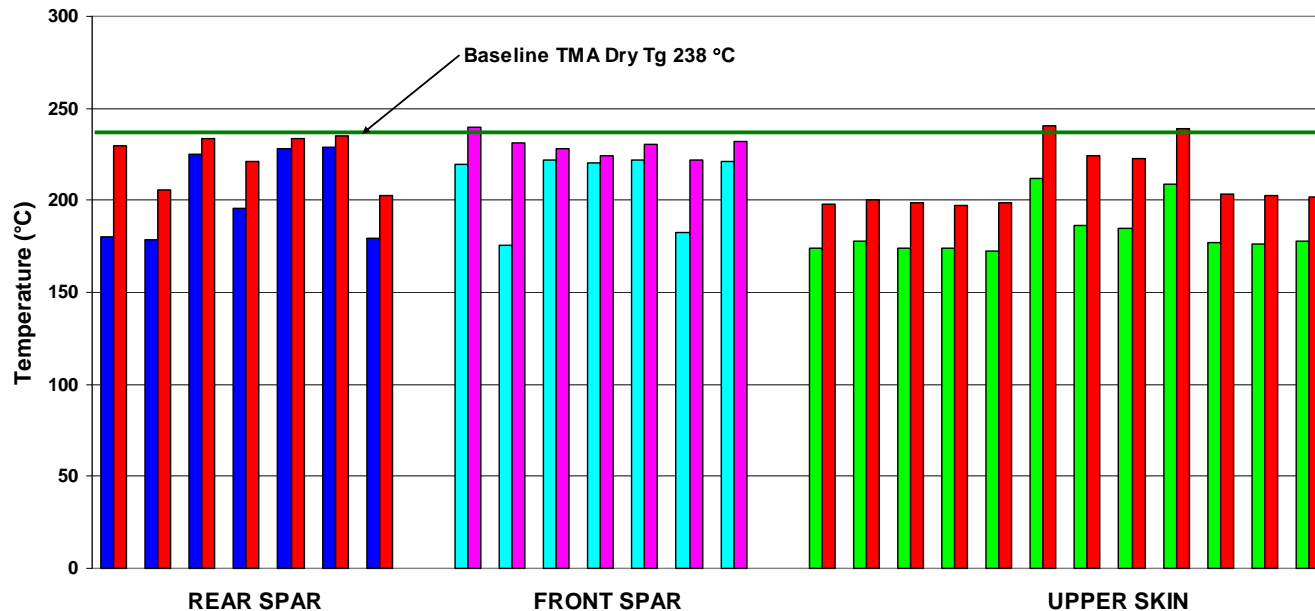

Wichita State University

- Non-Reversing heat flow curves reveal exotherms/ chemical reactions
- DSC heat of reaction values are extremely small (<6J/g) indicating a highly cross linked material (fully cured)
- Reversing heat flow curves reveal Tg
- Drying the specimen increased the cure onset (water acts as a plasticizer)
- Water content does not affect the degree of cure

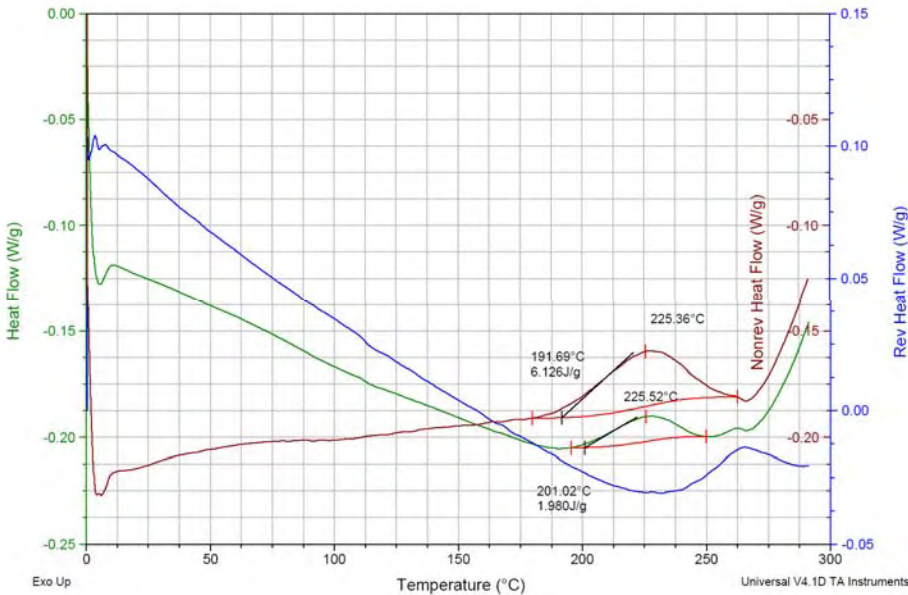

**DSC, Rib 7, as extracted**

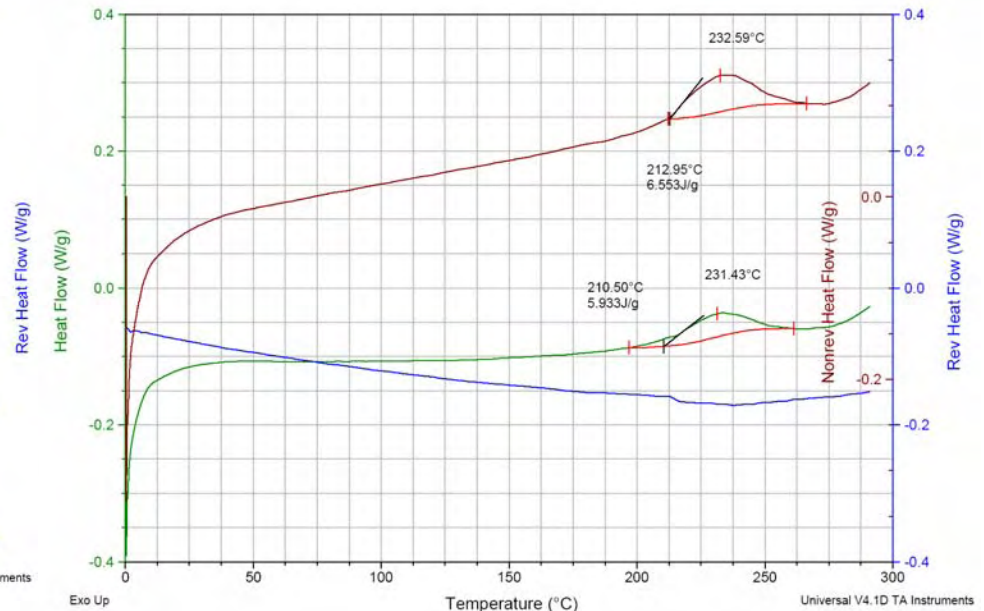

**DSC, Rib 7, dry**



- Spars have reached an almost fully cured status, postcuring occurred during the secondary bonding process (4% cure conversion increase wrt new material)
- Upper Skin has lower Heat of Reaction values than new material, additional curing has occurred during the life span of the structure (UV exposure), 2% cure conversion increase wrt new material

**% Cure Comparison Between New Material, Spars and Upper Skin**

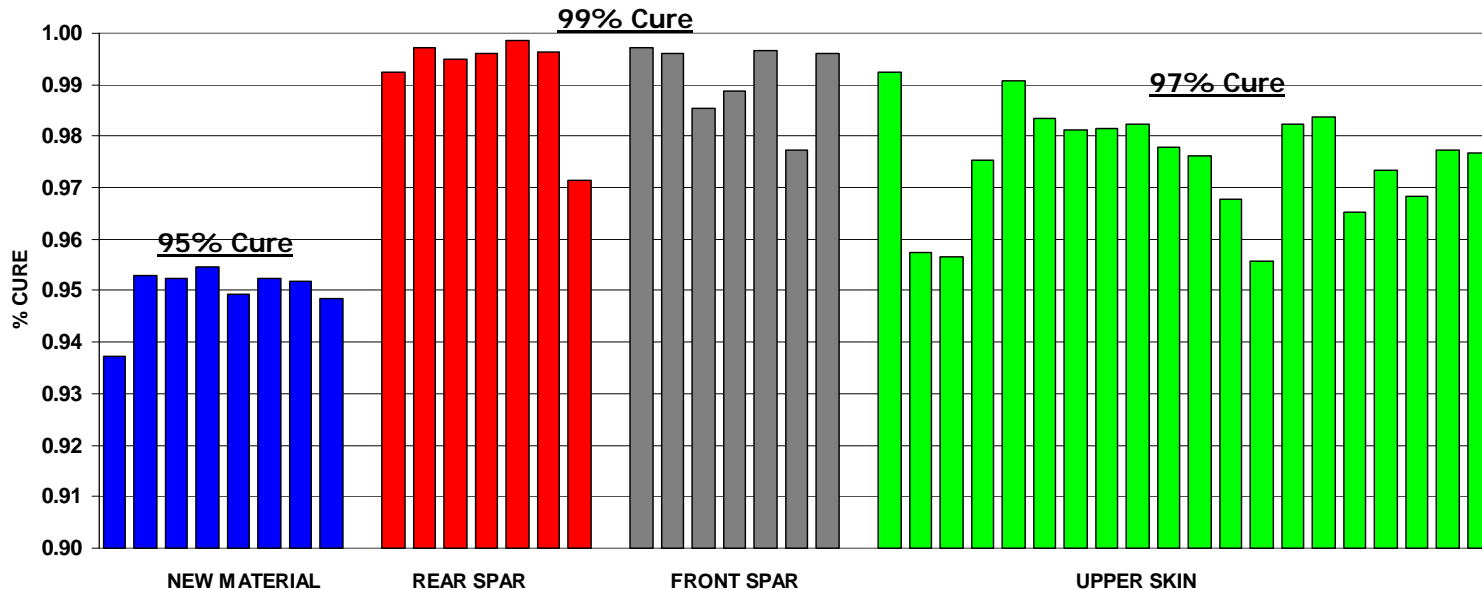

- Image analysis was performed to detect porosity/ micro-cracking and any evidence of aging in the structure.
- Both images show evidence of porosity embedded in the laminate. The flange cross section also shows evidence of microcracking initiating in the void areas.

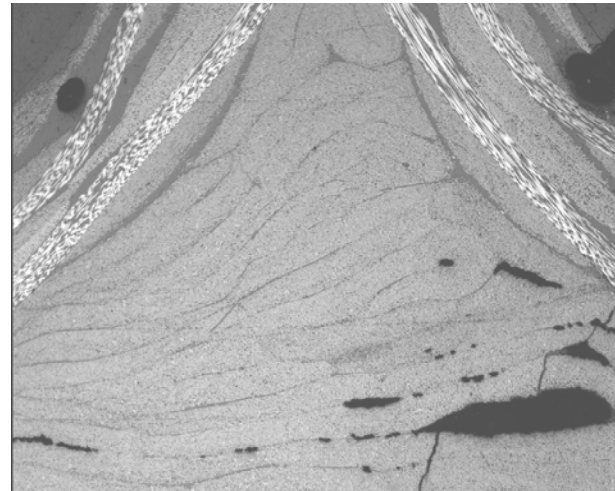
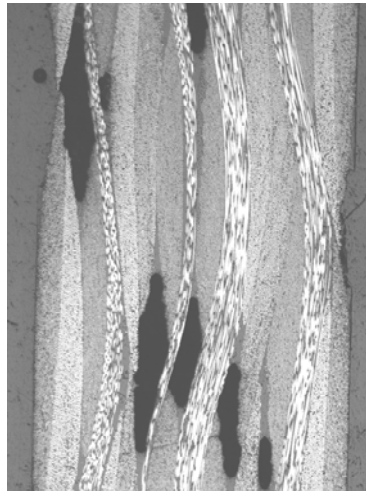

**X-section of stringer 2, rib station 2 at a magnification of 50x stringer web (left image) and flange (right image).**

Wichita State University

Mechanical Tests were conducted according to the 1980's requirements/ standards



**Tested Upper Skin Compression Coupons**



**Compression Test Set-up**

Wichita State University

# Mechanical Tests Results

## Lower Skin Compression Test Results

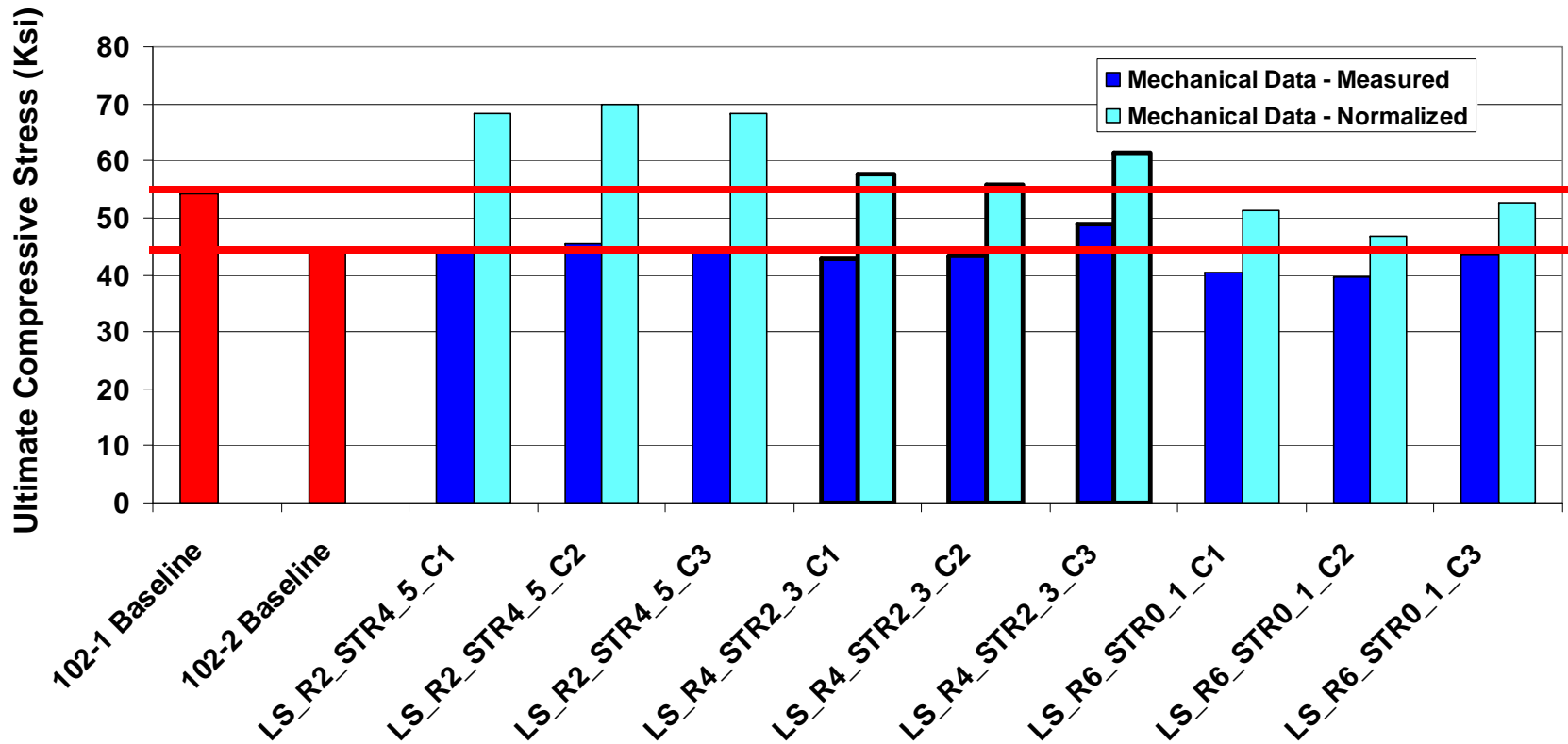

Wichita State University



# Mechanical Tests Results

## Lower Skin Compression Test Results, Modulus

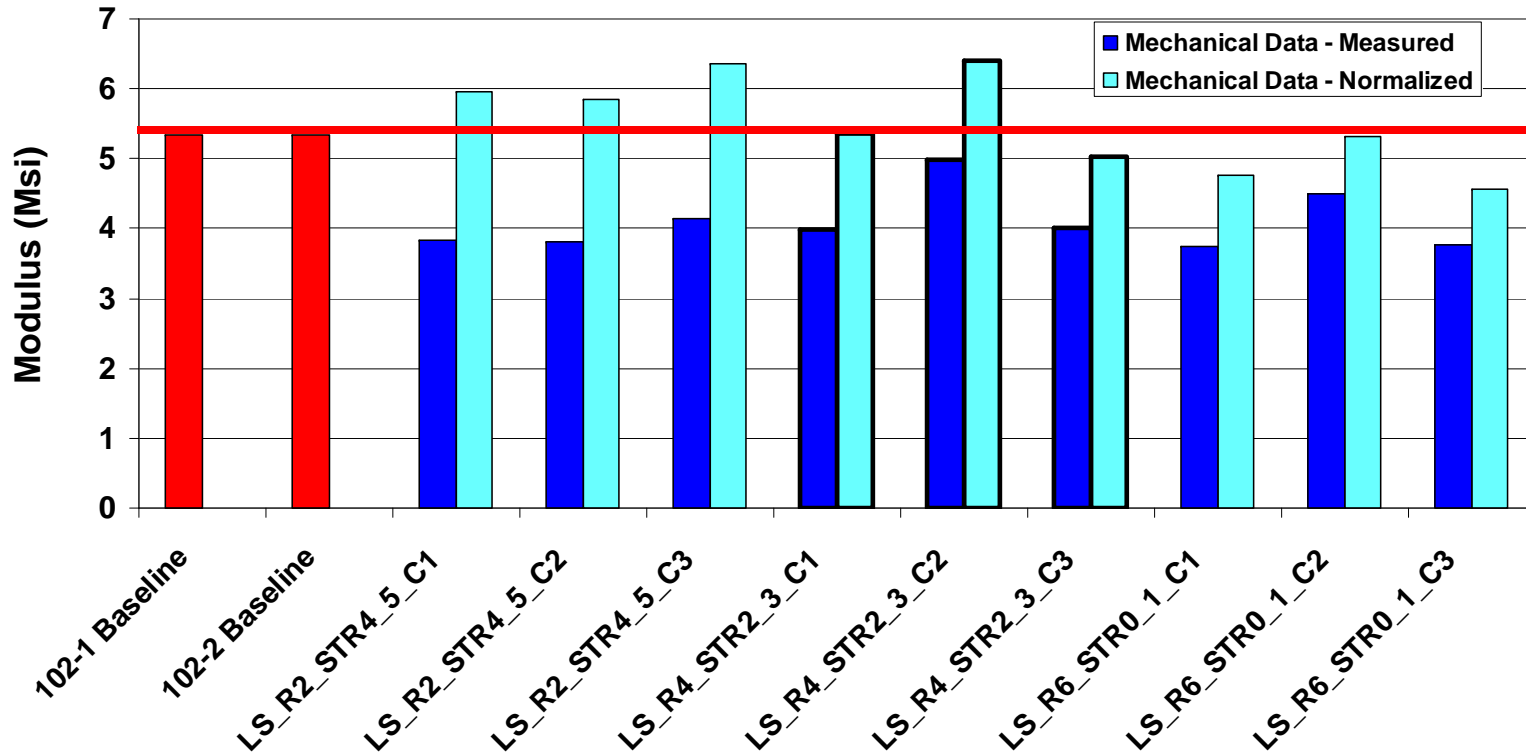

Wichita State University

# Mechanical Tests

Mechanical Tests were conducted according to the 1980's requirements/ standards



Tested Lower Skin Tension Coupons



Tension Coupon Test Set-up

# Mechanical Tests Results

## Lower Skin Tension Test Results

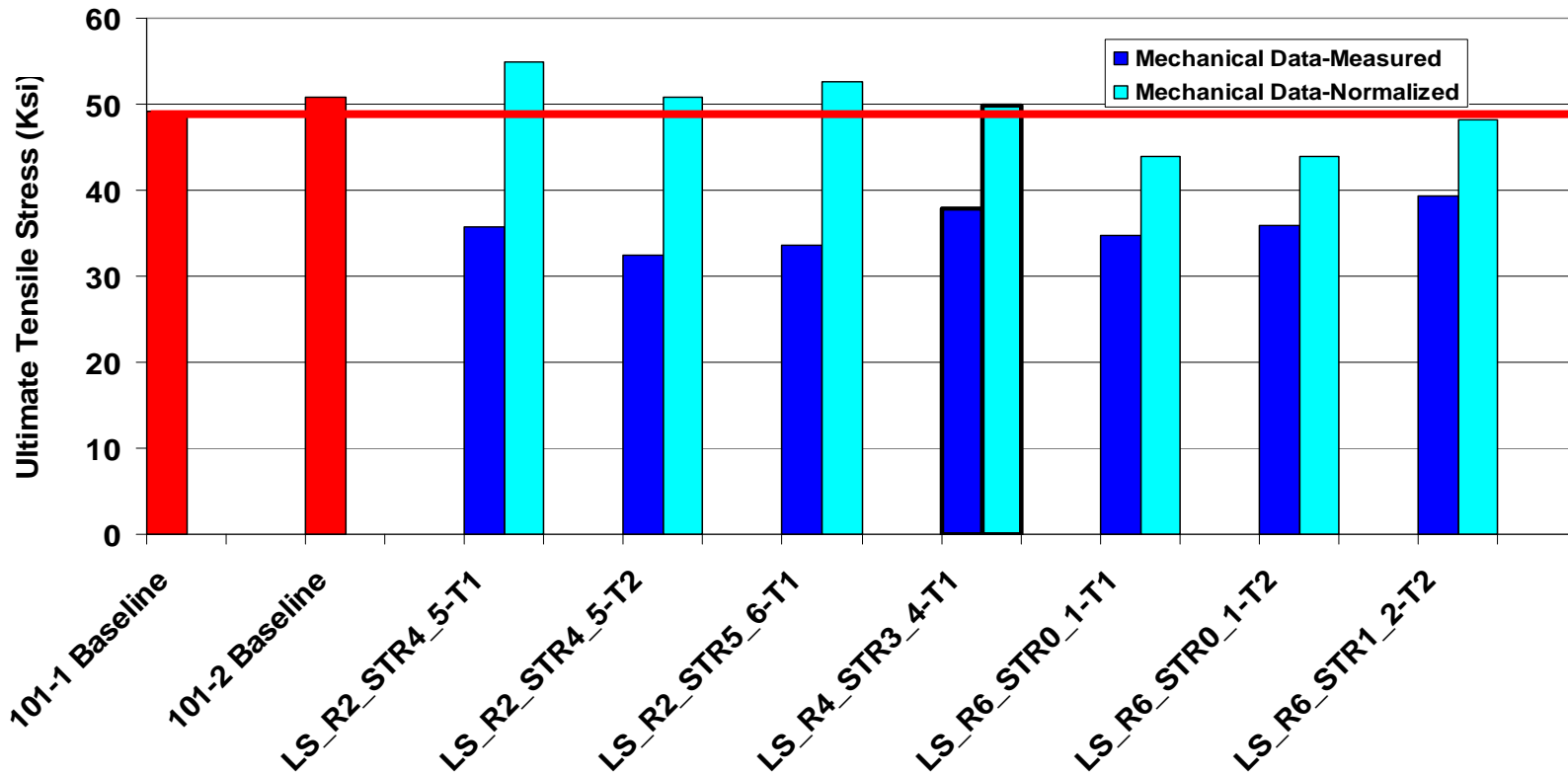

Wichita State University

# Mechanical Tests Results

Lower Skin Tension Test Results, Modulus

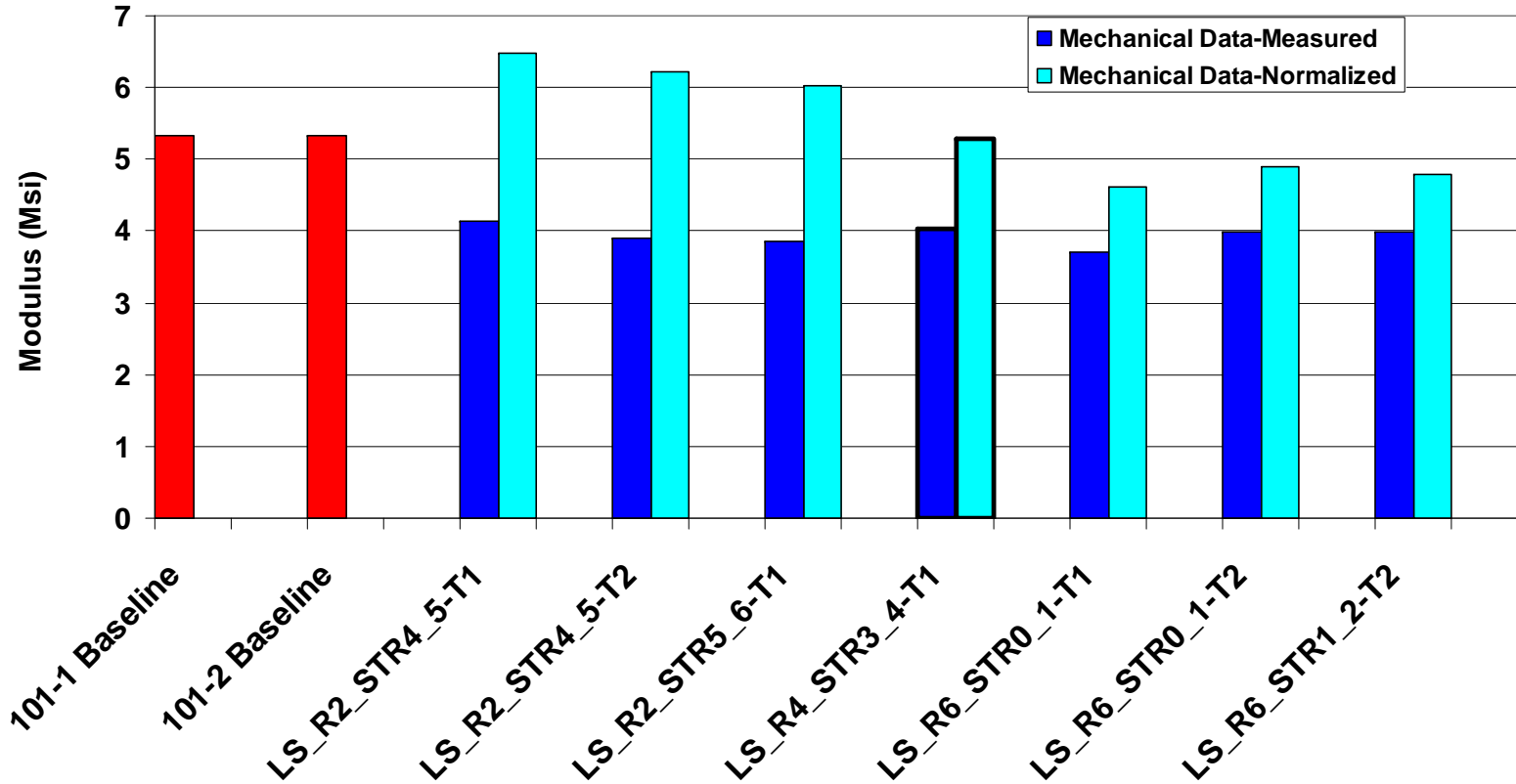

Wichita State University

# Element Testing-Crippling

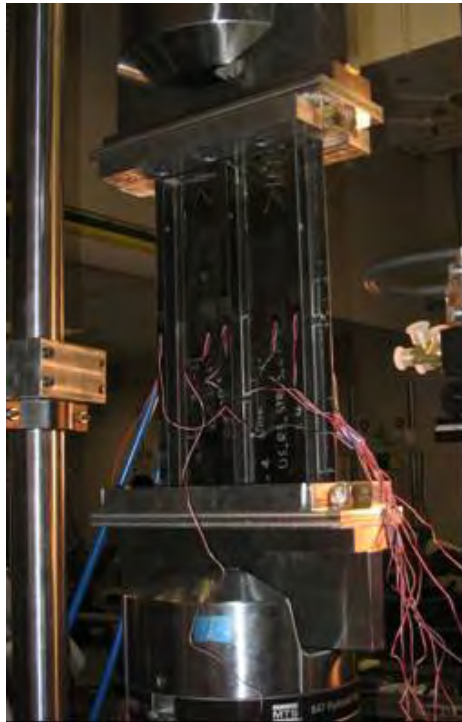

**Crippling Test Set-Up**

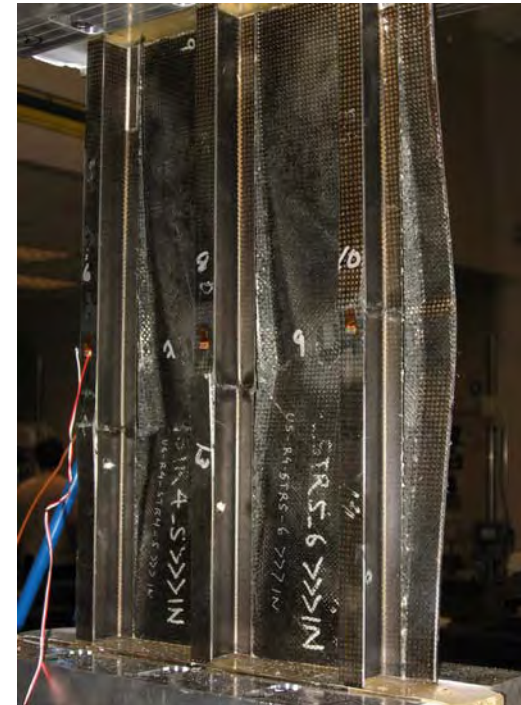
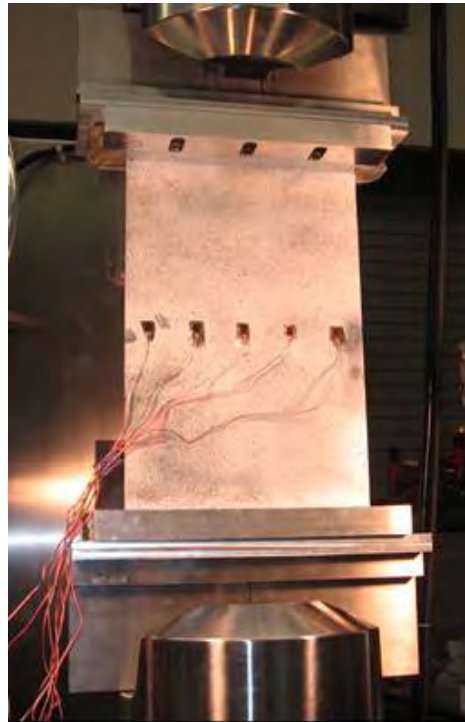

**Failed Specimen**

Wichita State University

# Element Testing-Crippling

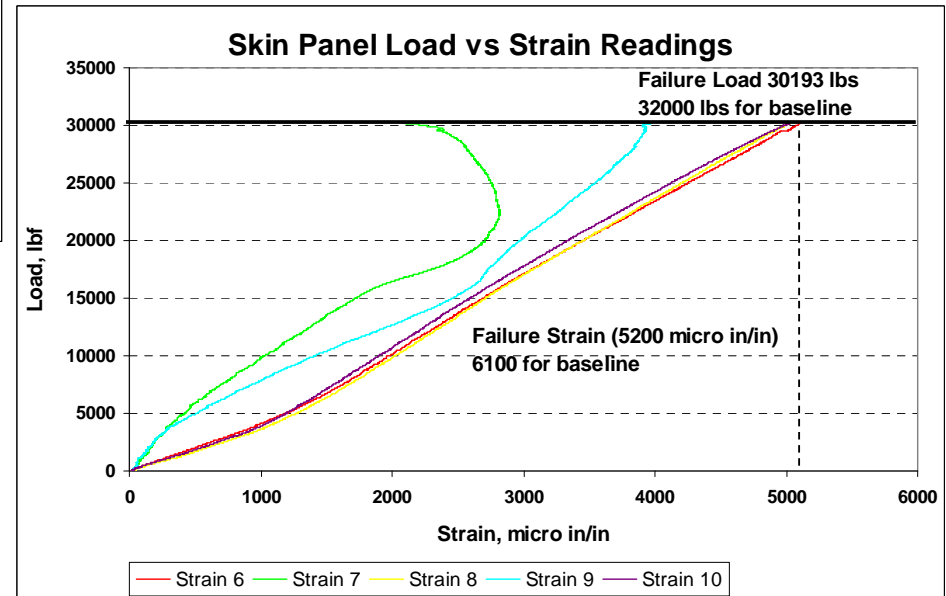
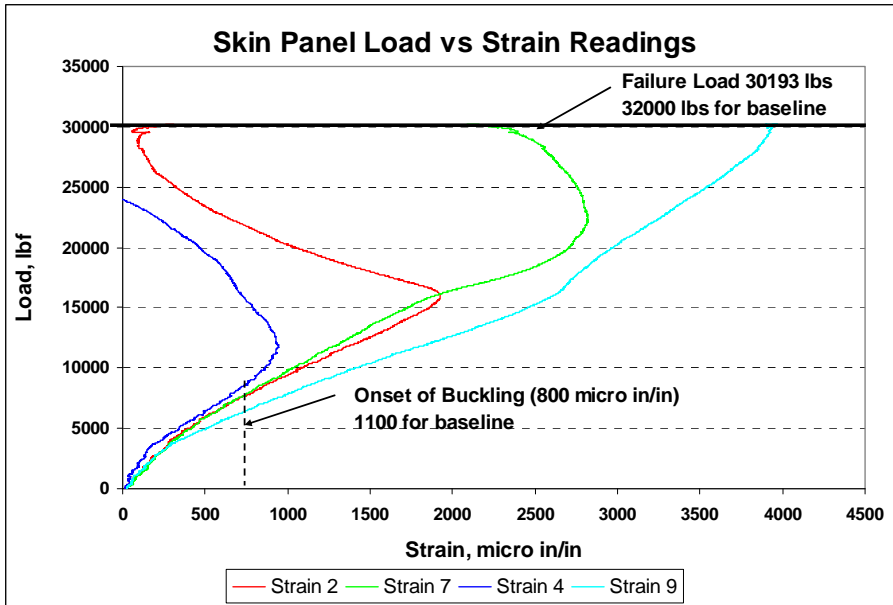

Wichita State University

# Conclusions

## Value of the results

- Structure held extremely well after 18 years of service: no obvious signs of aging to the naked eye such as pitting and corrosion as would a metal structure with a similar service history exhibit
- Physical tests showed moisture levels in the structure after 18 years of service as predicted during the design phase
- Thermal analysis results very consistent with those obtained for the left hand stabilizer
- Thermal analysis showed that the degree of cure of the spars is close to 100%, that additional curing may have occurred in the upper skin due to UV exposure (overall at least 95% cure was achieved in the structure)
- Significant improvements in composite manufacturing processes and NDI methods
- New material resin system thermal properties comparable to old material but strength is higher (fiber processing improvement)
- Teardown provides closure to a very successful NASA program and affirms the viability of composite materials for use in structural components

Wichita State University

# A Look Forward Benefits to Aviation

- Understand the aging of composite structures (current aging studies focused on metal structures)

Producibility large co-cured assemblies reduce part and assembly cost, however other costs should be taken into account, for example, when disposing of non-conforming assemblies

Supportability needs to be addressed in design. Composite structures must be designed to be inspectable, maintainable and repairable

- most damage to composite structures occurs during assembly or routine aircraft maintenance
- SRM's are essential to operating with composite structures, engineering information needed for in-service maintenance and repair