

# ***Standardization of numerical and experimental methods for crashworthiness energy absorption of composite materials***

***Paolo Feraboli & Associates!!***  
*Aeronautics & Astronautics*  
*University of Washington*  
*feraboli@aa.washington.edu*



*Presented at the AMTAS Fall Meeting*  
*October 25, 2007 -- 1:10 – 1:35 pm*



*In collaboration with*  
*Mostafa Rassaian (Boeing Phantom Works)*  
*and Xinran Xiao (General Motors R&D)*

# What is Crashworthiness?

## Reasons for accident fatality:

- *Contusion against objects.*
- *Excessive decelerations.*
- *Fire and smoke.*

## Conditions for survivability:

1. *maintaining sufficient occupant space*
2. *providing adequate occupant restraint*
3. *employing energy-absorbing devices*
4. *and allowing for a safe post-crash egress from the craft.*



## ***Automotive foundations***

- *Front Crumple zone.*
- *Tubular mentality.*

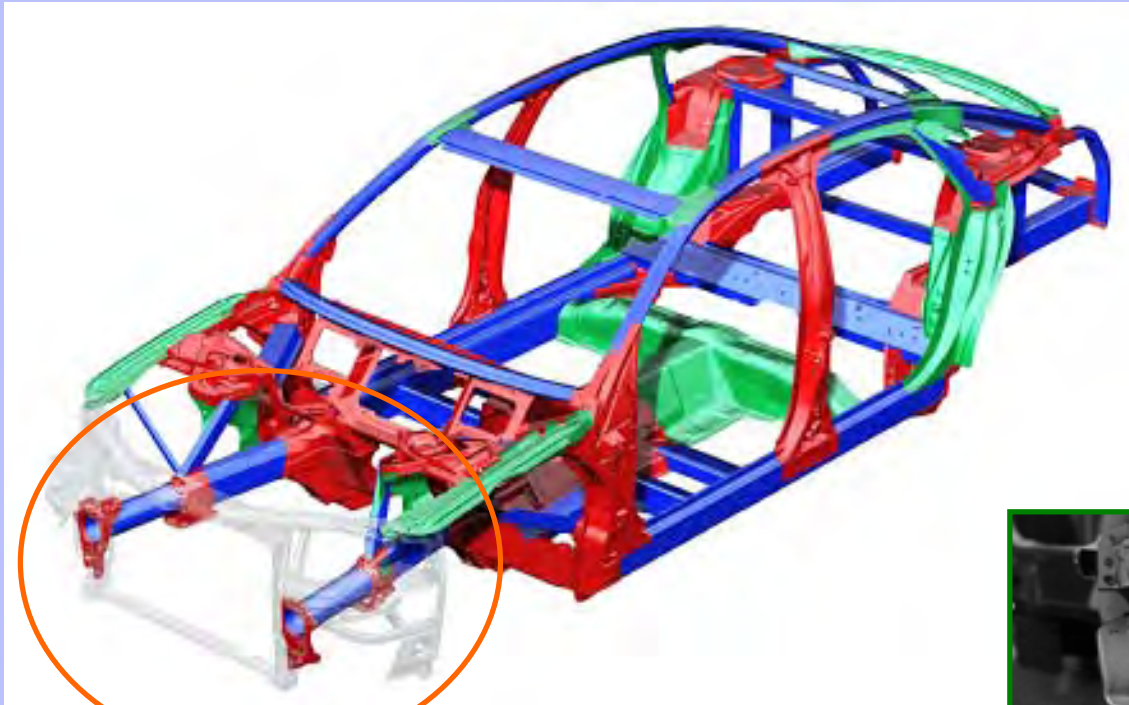

## Measuring Energy Absorption:

- *Specific Energy Absorption (SEA) is the Absorbed Energy per unit mass of crushed structure,*
- *Absorbed Energy is the total area under the Load-Displacement diagram*

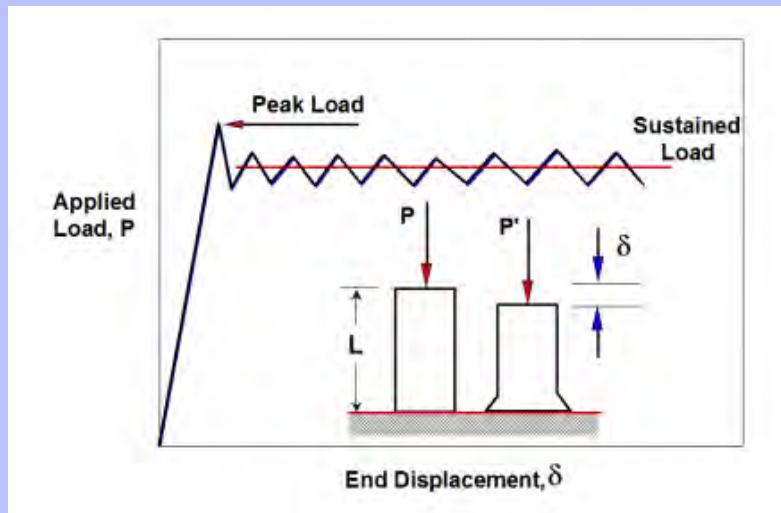

$$SEA = \frac{EA}{\rho \cdot A \cdot \delta} = \frac{\int_0^{\delta} F \cdot dl}{\rho \cdot A \cdot \delta}$$

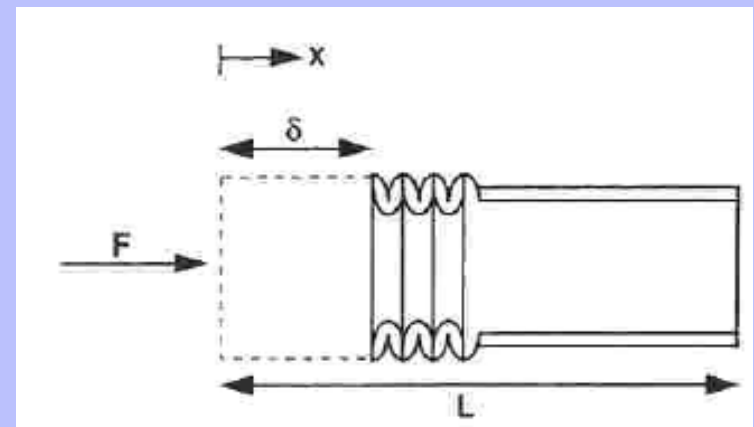

## SEA:

- *In general composites have a greater SEA potential*
- *but need to be carefully studied and understood.*

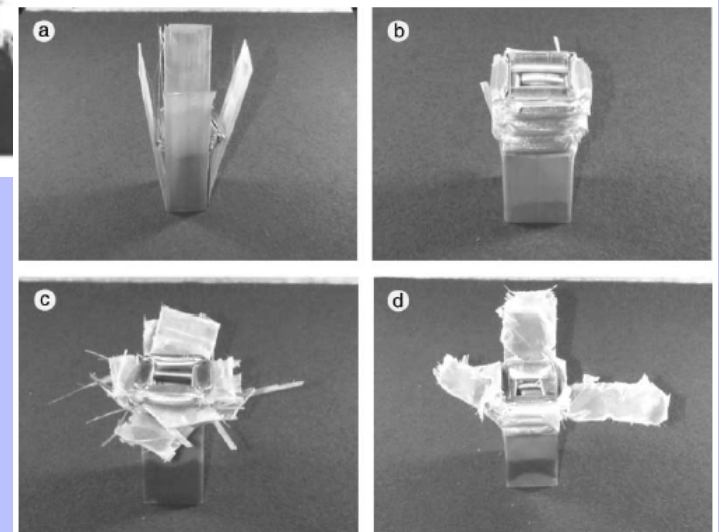
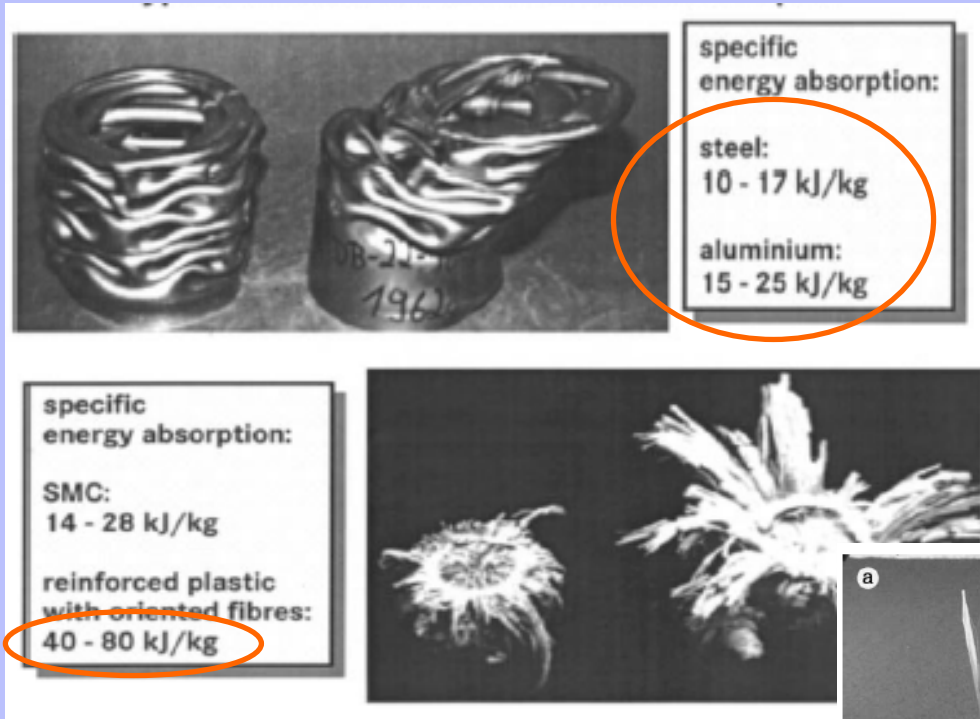



## ***Metal failure modes:***

- *Metal structures collapse by progressive yielding/ hinging.*

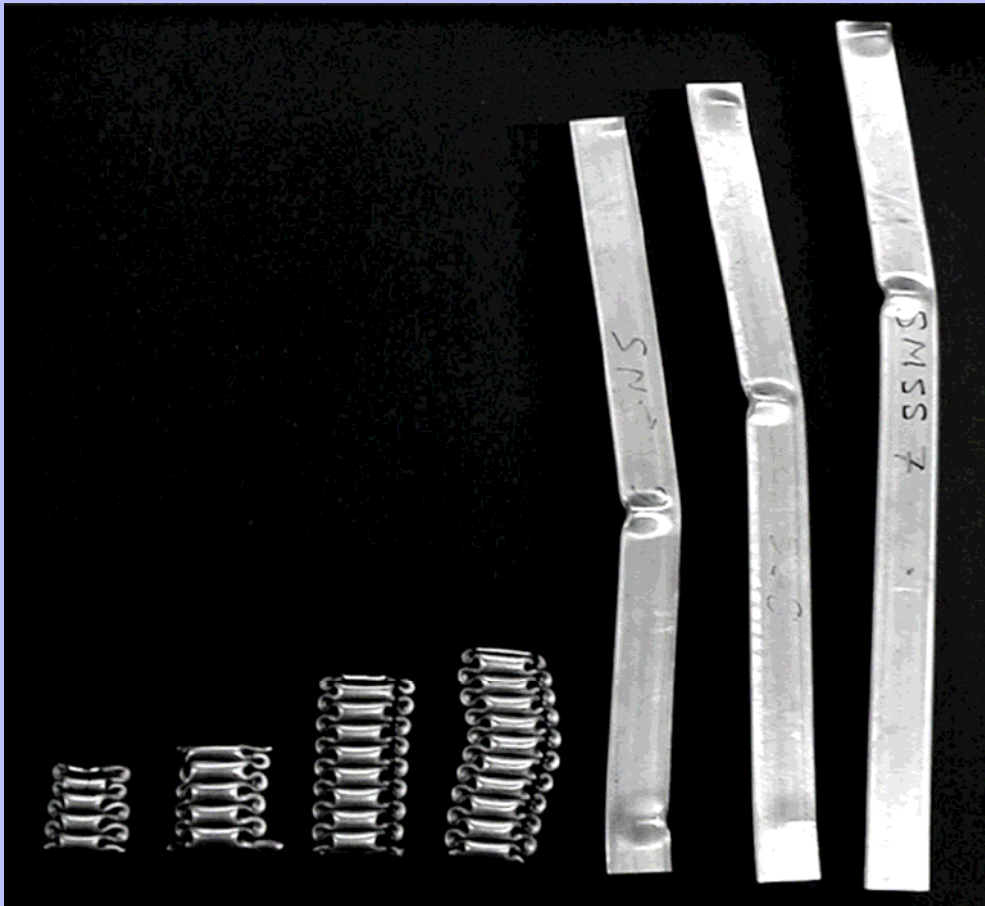

***Plastic folding***

## **Composite failure modes:**

- *Brittle compressive and shear fracture of resin and fibers*
- *Bending and friction of lamina bundles/ fronds*
- *Interlaminar crack growth/ delamination propagation*



### **Fragmentation/ splaying**

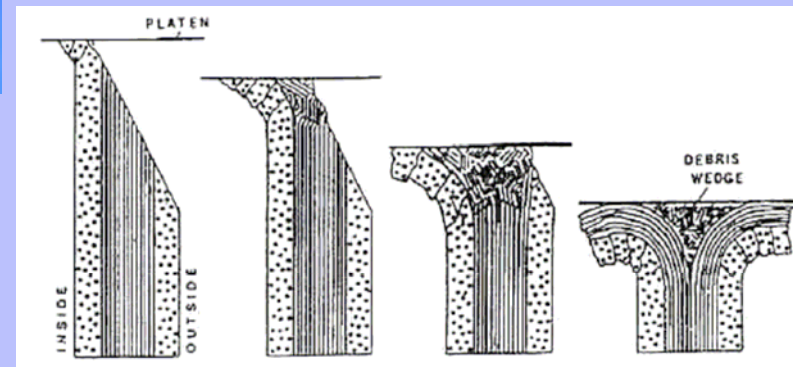

# Rotorcraft subfloor

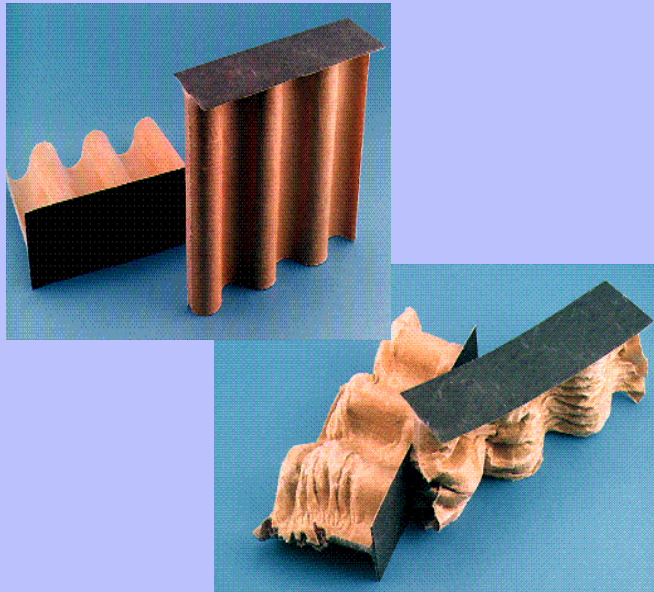
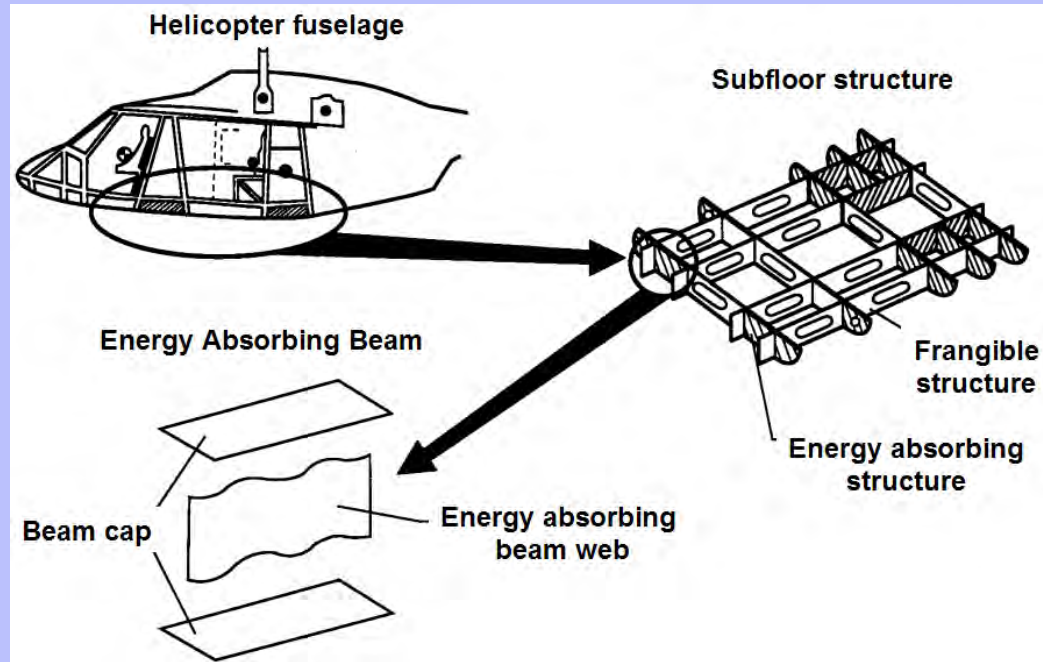



## CMH-17 Crashworthiness Working Group

- 
- **Numerical standardization**
    - *Current FE modeling strategies are not predictive*
    - *Round Robin initiated involving major FE explicit dynamic codes to characterize material models and modeling strategies*
    - *Goal is to develop guidelines for “plug-and-play” capabilities*
  - **Experimental Standardization**
    - *No existing test standard to determine SEA*
    - *No way to screen material systems/ forms/ lay-ups*
    - *Material suppliers, OEM’s and regulators need to speak one language*
    - *Goal is to develop test standard and design guidelines*

## ***Numerical Standardization:***

- *Non-linear, dynamic simulation requires explicit FEA codes*
- *Common commercial codes used in this field are:*
  - *LS-DYNA (LSTC)*
  - *ABAQUS Explicit (SIMULIA)*
  - *[PAMCRASH (ESI)]*
  - *[[RADIOSS (ALTAIR)]]*
  
- *Each code is unique for:*
  - *Material models*
    - *Failure criteria implementation*
    - *Strength and stiffness degradation strategies*
  - *Other code parameters: contact definition damping, time steps, etc...*

## ***Numerical Standardization:***

### *LS-DYNA*

- *Used as benchmark in the field for years*
- *Pre-existing material models*

MAT	Title	Brick	Shell	Degradation Law
22	Composite Damage	y	y	Progressive failure
54/55	Enhanced Composite damage		y	Progressive failure
58	Laminated Composite Fabric		y	Damage Mechanics
59	Composite Failure	y	y	Progressive failure
161	Composite MSC	y		Damage Mechanics
162	Composite MSC	y		Damage Mechanics

## ***Numerical Standardization:***

- *Composite constitutive models are continuum mechanics models and treat composites as orthotropic linear elastic materials within a failure surface, which depends on the failure criterion adopted.*
- *Beyond failure, elastic properties are degraded according to degradation laws:*
  - *progressive failure models (PFM)*
  - *continuum damage mechanics (CDM) models.*



## ***Numerical Standardization:***

- *PFM use a ply discount method to degrade the elastic properties of the ply from its undamaged state to a fully damaged state*
- *Elastic properties are dependent on field variables.*
- *After a failure index has exceeded 1.0, the associated user-defined field variable is made to transit from 0 (undamaged) to 1 (fully damaged) instantaneously.*
- *LSDYNA MAT 22, 54, 55 and 59*

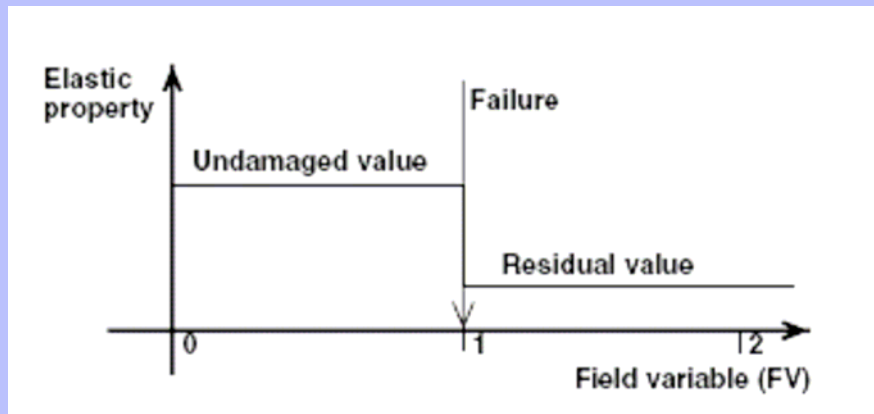

## ***Numerical Standardization:***

- *CDM describe the collective influence of damage through the use of internal damage variables, which assume continuous values between [0, 1]*
- *LSDYNA MAT 58, 161*
- *Damage variables cannot be measured directly: need to relate microstructure deterioration to macroscopic response*
- *CDM can be microscopic, mesoscopic and macroscopic*
  - *Micro and mesoscopic models relate specific damage mechanisms to global stress-strain responses.*
  - *Macroscopic or phenomenological models treat various damage mechanisms in a smeared fashion.*

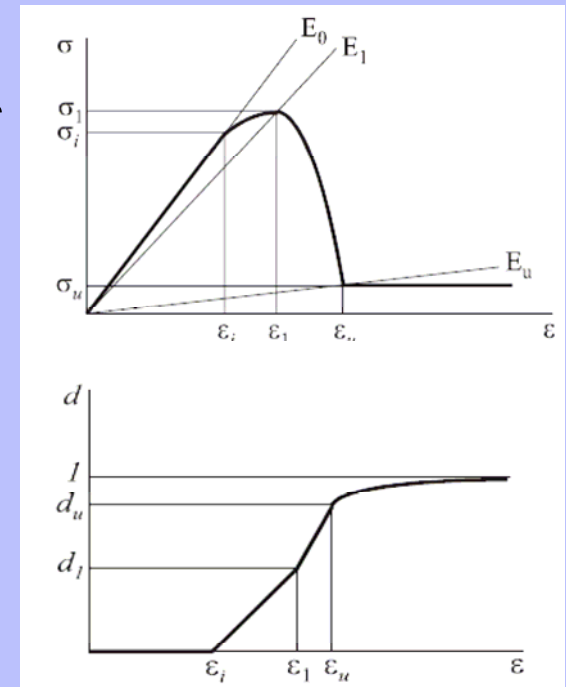

## Numerical Standardization:

### Progressive Failure Models

- MAT54/55, Enhanced composite damage model (shell only)  
5 strength parameters

$X_T$  - longitudinal tensile strength,  $X_c$  - longitudinal compression strength

$Y_T$  - transverse tensile strength,  $Y_c$  - transverse compression strength

$S_c$  - shear strength,  $\beta$  - weighting factor for shear

10 additional parameters for failure

Time failure: TFAIL

Reduction at crush front: SOFT

After matrix compressive failure:  $XT=XT*FBRT$ ,  $XO=YC*YCFAC$  (54)

MAT54: maximum strain for layer removal

DFAILM, DFILS, DFAILT, DFAILC, EFS

Fiber tensile	$e_f^2 = \left(\frac{\sigma_{11}}{X_T}\right)^2 + \beta\left(\frac{\sigma_{12}}{S_c}\right)^2 - 1 > 0, E_1 = E_2 = G_{12} = \nu_{21} = \nu_{12} = 0$
Fiber compression	$e_f^2 = \left(\frac{\sigma_{11}}{X_c}\right)^2 - 1 > 0, E_1 = \nu_{21} = \nu_{12} = 0$
MAT54	Chang matrix failure
Matrix tensile	$e_m^2 = \left(\frac{\sigma_{22}}{Y_T}\right)^2 + \left(\frac{\sigma_{12}}{S_c}\right)^2 - 1 > 0, E_2 = G_{12} = \nu_{21} = 0$
Matrix compression	$e_d^2 = \left(\frac{\sigma_{22}}{2S_c}\right)^2 + \left[\left(\frac{Y_c}{2S_c}\right)^2 - 1\right]\frac{\sigma_{22}}{Y_c} + \left(\frac{\sigma_{12}}{S_c}\right)^2 - 1 > 0, E_2 = G_{12} = \nu_{21} = \nu_{12} = 0, X_c = 2Y_c$
MAT55	Tsai-Wu criterion for matrix failure
	$e_{md}^2 = \left(\frac{\sigma_{22}}{Y_T Y_c}\right)^2 + \left(\frac{\sigma_{12}}{S_c}\right)^2 + \frac{(Y_c - Y_T)\sigma_{22}}{Y_c Y_T} - 1 > 0$

## ***Numerical Standardization:***

- *Key ingredients for a good simulation are:*

- *Material input properties*
- *Other code parameters*

- *In both cases there are several factors that require systematic calibration.*
  - *How do various material models compare?*
  - *Are there more suitable ones for a specific problem?*
  - *What are things to watch out for?*
- 
- *The methodology used for crashworthiness is identical to the one used for other dynamic events, such as FOD and ballistic penetration, bird and hail strike modeling, blast resistance, etc.*



## **Numerical Standardization:**

- *Round robin to evaluate the effectiveness and robustness of equivalent numerical models using a common, predefined target structure.*
- **Common material:** *carbon/epoxy TORAYCA fabric certified during the AGATE program (P.O.C. Leslie Cooke). Generate input material properties required.*
- **Common geometry:** *corrugated plate specimen.*
- **Common laminate lay-up:**  $[(0/90)]_{3s}$  – *12 plies*
- **Common crush initiator, test velocity, surface friction**
- **Deliverable:** *For every submission*
  - *Compile simulation datasheet*
  - *Exhibit force-deflection curve and SEA curve*
  - *Exhibit animation/ sequential figures of failure morphology*

## Numerical Standardization:

- *Simulation input datasheet*
- *Number of parameters!!*

Table of inputs and model parameters	Variable name	Value	Units (for consistency)
FEA code used			
Version			
Processor used			
Number of CPUs			
Operating System			
CPU - Solution time			
Number of elements			
Element type			
Mesh size			
Material type/number			
Material model (stress-strain table or curve input)			
Failure Criterion			
Damage progression criterion			
Time step increment			
Element deletion speed			
loading condition			
boundary condition			
damping definition			
hourglass control			
Contact type			
Longitudinal modulus	E11		
Transverse modulus	E22=E33		
Major Poisson's Ratio	$\nu_{12}$		
In-plane shear modulus	G12		
Through-thickness Shear Modulus	G23		
Bulk modulus of failure material			
Longitudinal tensile strength			
Longitudinal compressive strength			
Transverse tensile strength			
Transverse compressive strength			
In-plane Shear strength			
Maximum matrix strain			
Maximum shear strain			
Maximum fiber tensile strain			
Maximum fiber compressive strain			
Others			

## ***Experimental Standardization:***

- *Self-stabilizing specimens*
  - *Tubular (several dozens)*
  - *Semicircular (DLR)*
- *Specimens requiring special fixtures*
  - *Flat plate (NASA/ARL, Engenuity)*
  - *Flat frond (DoE, ACC, Ford)*
- *Tubular specimens are costly and complex to manufacture, plus closed section characteristic is added complexity.*
- *Flat specimen is appealing because simple and cheap, but effect of fixture is unknown and difficult to characterize and model.*
  - *Need self-supporting, simple, repeatable specimen*

## Experimental Standardization:

- NASA/ ARL fixture
- Lack of unsupported area where the debris can move freely.
- Knife-edge supports prevent “outward brooming” of plies.
- Trigger shape sensitivity issues
- Knife contact/ indentation variability
- Results do not compare well with tubular specimens

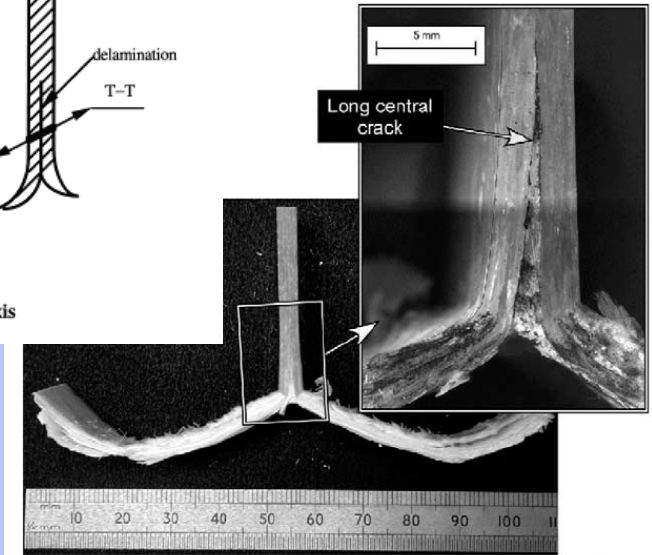
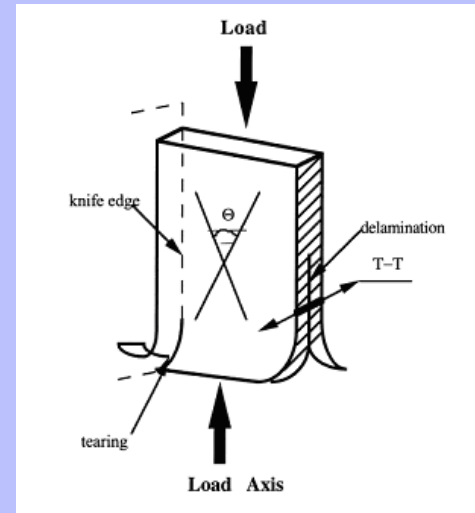
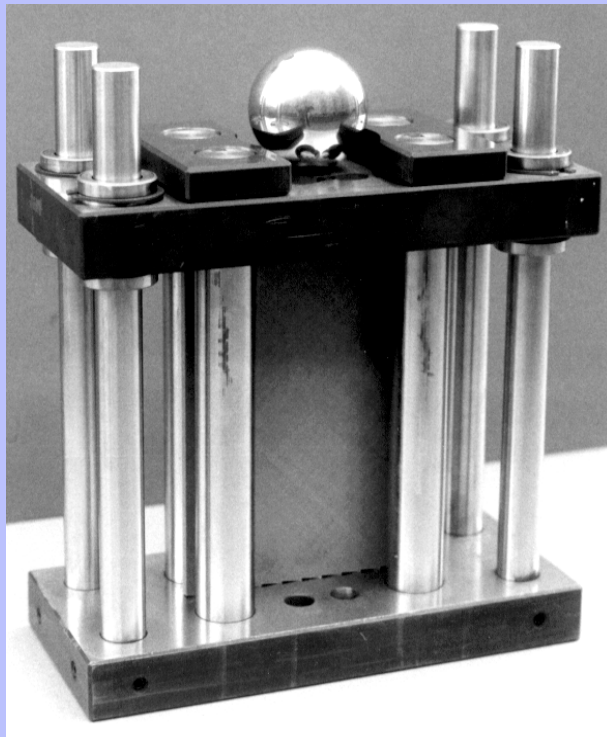



## Experimental Standardization:

- *Engenuity Ltd. fixture*
- *Friction issue partially resolved (Delrin sliders)*
- *Trigger issue partially resolved (jagged vs chamfer)*
- *Extra parameter: spacer height (height of unsupported gap between support and base) --- affects measured SEA*
- *Thorough calibration necessary for every material system and lay-up – measurement is not robust.*

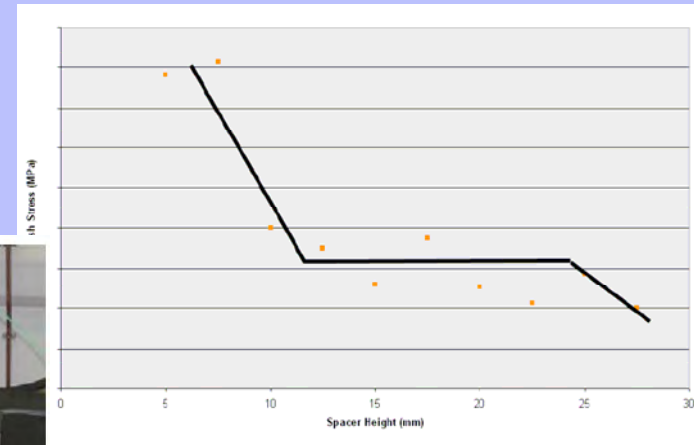
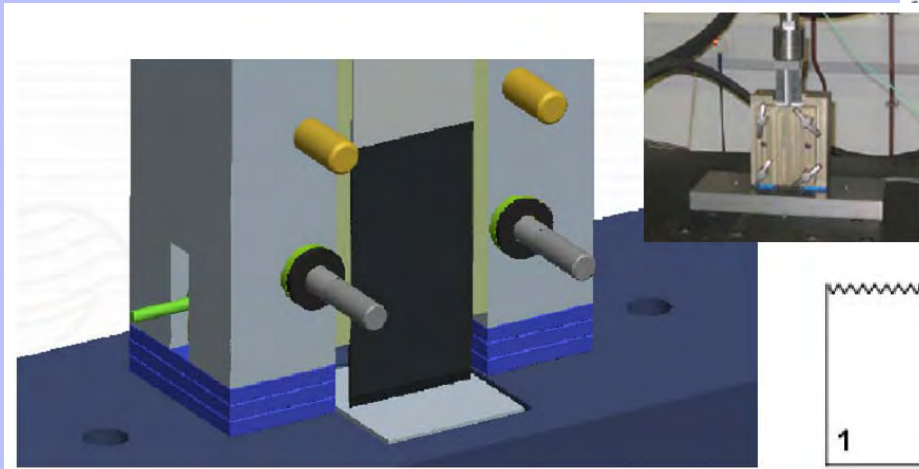

## Experimental Standardization:

- DLR specimen
- Nearly self-supporting -- requires bonding to a purposely machined aluminum base
- Easy to manufacture
- Used to calibrate PAMCRASH models for Airbus

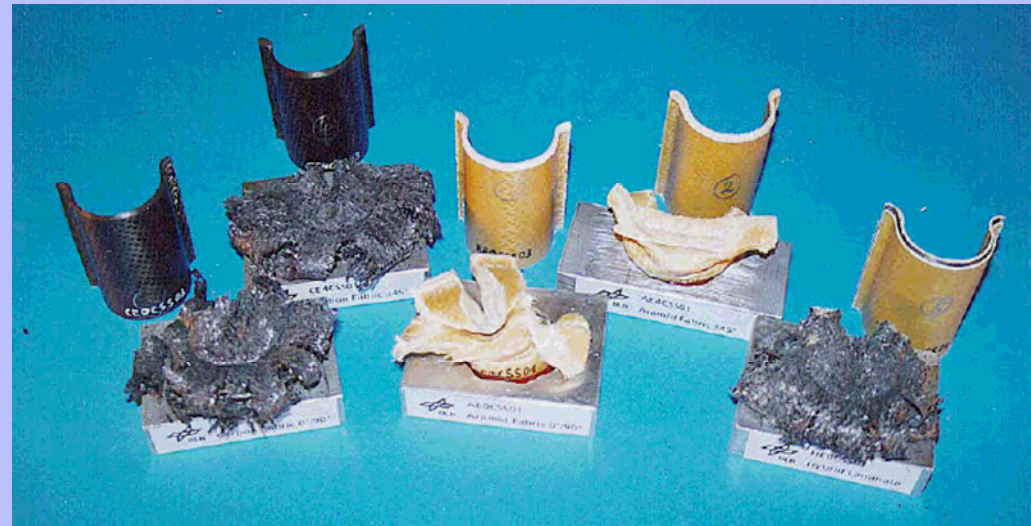
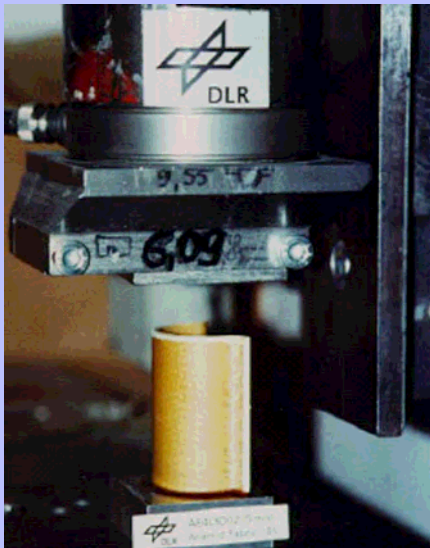

Height  $\approx$  67 mm



Isometric View

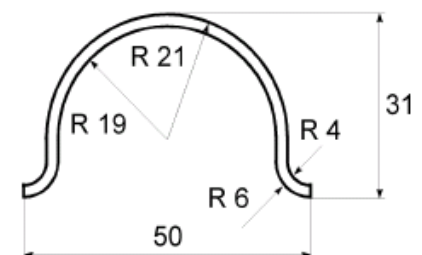

## Experimental Standardization:

- *Proposed specimen*
- *Truly self-stabilizing: no fixture necessary*
- *No autoclave or mandrel necessary*
- *Less complexity, cost and uncertainty than tubular specimen*

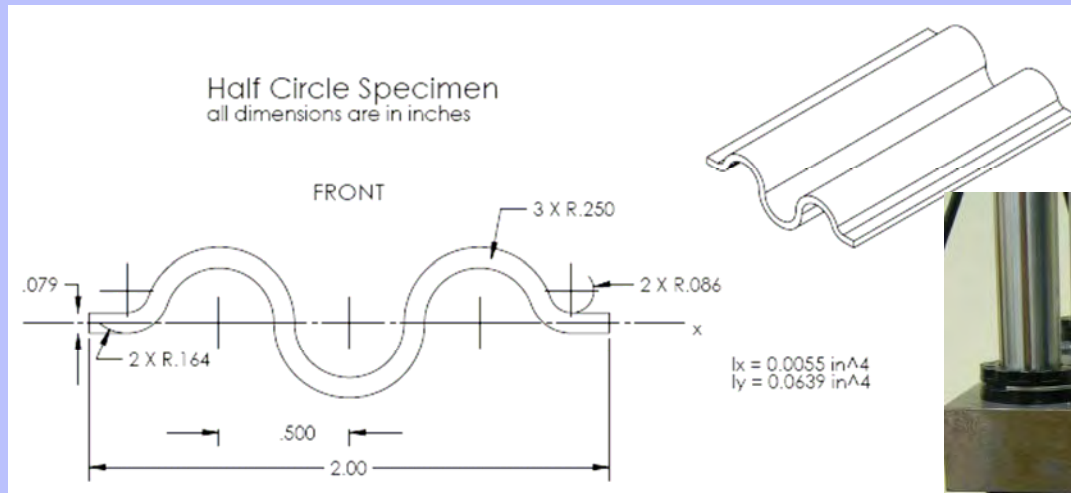



## Corrugated Specimen:

- Specimen after testing,
- Load, SEA, Total Energy vs. Stroke

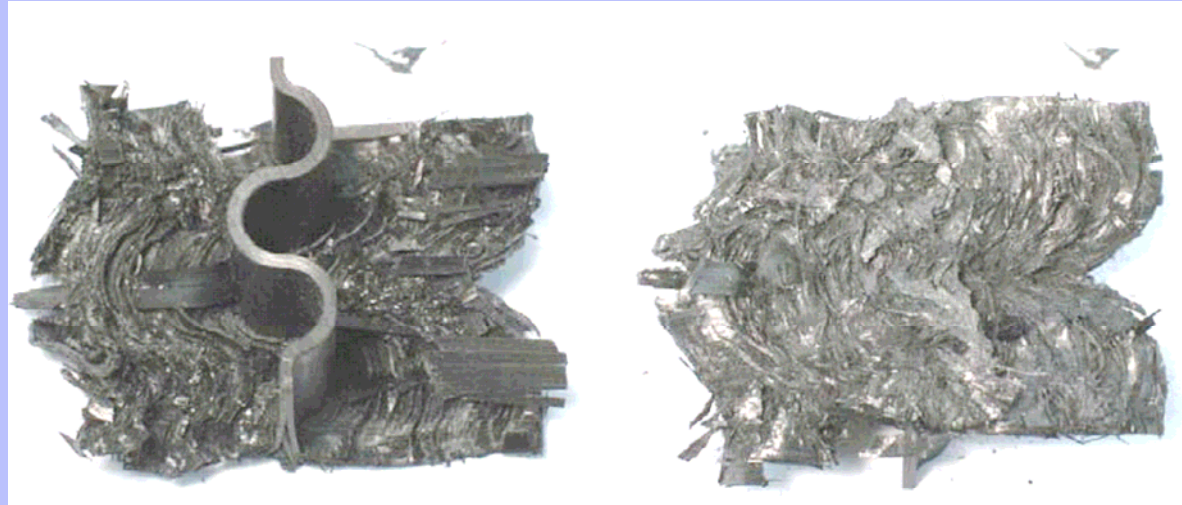

TOP

BOTTOM

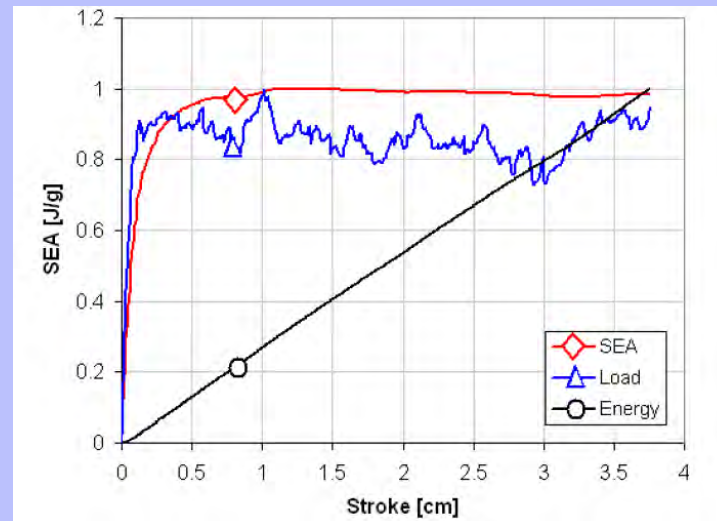



## ***Experimental Standardization:***

- *Need to preform systematic comparison of:*
  - *Flat plate specimens using modified NASA/ ARL/ Engenuity fixture*
  - *Corrugated web specimens*
  - *C-channel sections (indicative of floor stanchions)*
  - *Square tubes*

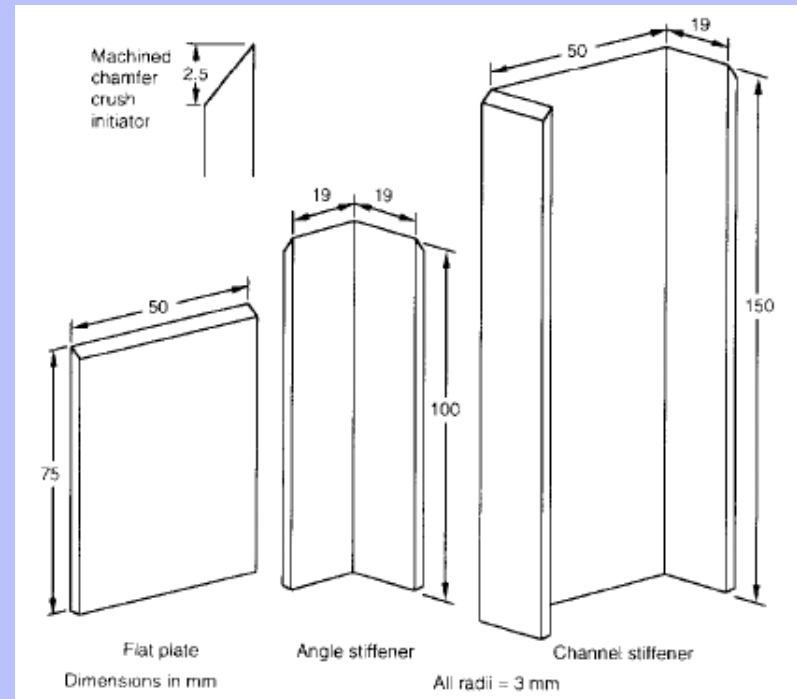

## **Conclusions:**

- *This project will aim at characterizing analytical and experimental aspects of composites crash behavior*
- **Analytically**, mainstream FEM codes will be tested systematically to compare modeling strategies and derive best practices for simulation
- **Experimentally**, existing test methods will be compared to identify robustness and repeatability characteristics and develop test standards and design guidelines



## ***Acknowledgments:***

- *The co-investigators*
  - *Mostafa Rassaian, Boeing Phantom Works*
  - *Xinran Xiao, General Motors*
- *The associates*
  - *Tyler Cleveland*
  - *Francesco DeLeo*
  - *Francesca Garattoni*
- *The ones that matter.....*
  - *Patrick Stickler, The Boeing Co.*
  - *Randy Coggeshall, Boeing Commercial Airplanes*
  - *Al Miller, Boeing Commercial Airplanes*
  - *Larry Ilcewicz, FAA CSTA Composites*
  - *Allan Abramowitz, FAA Crash Program Monitor*
  - *Curt Davies, FAA JAMS Program Manager*