

# Certification of Discontinuous Composite Material Forms for Aircraft Structures

presented by

Mark Tuttle

Dept Mechanical Engineering  
University of Washington

---

# Certification of Discontinuous Composite Material Forms for Aircraft Structures

---

- Objective: Simplify certification of DFC aircraft parts
  - Technical Approach: HexMC (a DFC being used on the B787) selected as a model material. For this material, perform:
    - Experimental studies of HexMC mechanical behaviors, starting with simple coupon-level specimens and progressing towards “complex” parts
    - Study effects of processing (e.g., impact of material flow during molding on stiffness and strength)
    - Develop stochastic modeling approaches
    - Compare measurements with analytical-numerical predictions
-



# Certification of Discontinuous Composite Material Forms for Aircraft Structures

---

## Principal Investigators & Researchers (UW):

- PIs: Mark Tuttle and Paolo Feraboli
- Grad Students: Tory Shifman (MSME '11), Marco Ciccu, Bonnie Wade, Brian Head

## FAA Technical Monitor

- Curtis Davies

## Other FAA Personnel Involved

- Larry Ilcewicz

## Industry Participation

- Boeing: (primarily ) Bill Avery
  - Hexcel: (primarily) Bruno Boursier and David Barr
-

## Topics of earlier papers/presentations

- HexMC coupon tests (e.g., UNT, OHT, UNC, OHC); properties exhibit relatively high levels of scatter; HexMC is notch insensitive  
Feraboli et al: (a) *J. Composite Materials*, Vol 42, No 19  
(b) *J. Reinf. Plastics and Composites*, Vol 28, No 10  
(c) *Composites Part A*, Vol 40
- “High-flow” and “ply-drop” panel tests: material flow causes modest chip/fiber alignment (optical microscopy) and measureable change in stiffness and strength (coupon tests)  
Tuttle/Shifman: [JAMS '09 & '10](#), [AMTAS Fall '09 and Spr '10](#)
- FEM modeling of stiffness/strength via stochastic laminate analogy  
Feraboli/Ciccu: [JAMS '10 & '11](#), [AMTAS Fall '10](#)
- Measurement/prediction of elastic bending stiffness of HexMC angle beams with non-symmetric cross-sections  
Tuttle/Shifman: [JAMS '11](#), [AMTAS Fall '10](#)

## Activities during past 12 months:

- Tuttle/Shifman/Head:
    - HexMC angle beam tests
      - Completed elastic bending tests (54 tests at 6 beam orientations)
      - Completed bending tests to failure (15 tests at 1 beam orientation)
    - Preliminary FEM analyses of angle beams (ANSYS)
    - Developed facility and instrumentation to test HexMC intercostals (intercostal tests/analyses to be performed during 2011-12)
  - Feraboli/Ciccu/Wade:
    - Preliminary FEM analyses of angle beams using stochastic laminate analogy (NASTRAN)
    - Open-hole tension tests with
      - Varied d/w ratios
      - Use of DIC to measure variations in strain concentration field near hole
-

Focus of this presentation:

## I. HexMC Angle Beams:

- Summary of elastic bending test results
- Summary bending tests to failure (15 tests at 1 beam orientation)
- Preliminary FEM analyses of angle beams

## II. Description of HexMC intercostal test facility and instrumentation

---

# HexMC Angles

Compression molded by Hexcel

- 2.5 x 43 mm ("Small")  
(0.097 x 1.7 in )
- 4.8 x 64 mm ("Medium")  
(0.188 x 2.5 in )
- 4.8 x 89 mm ("Large")  
(0.188 x 3.5 in)

After receipt all beams were machined to 36 cm (14 in) length at the UW



# Strain Gaging

- A total of 8 strain gages bonded at 2 cross sections for all specimens
- 1 inch gage length gages were used to obtain a nominal axial strain measurement

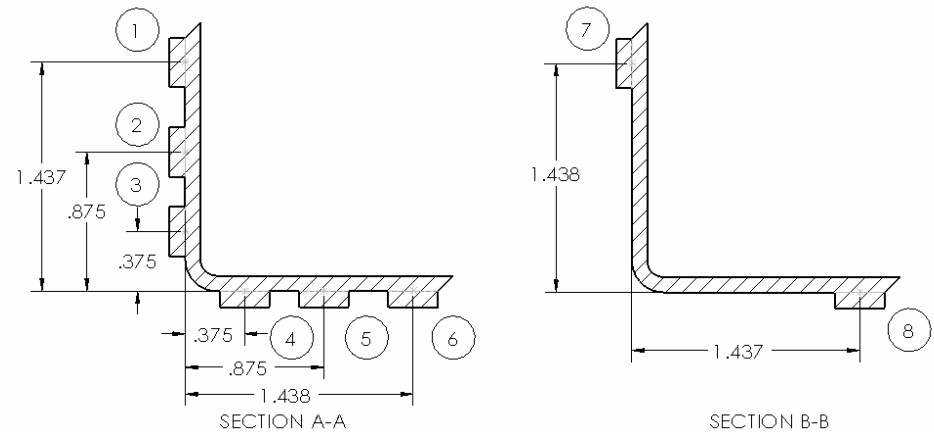
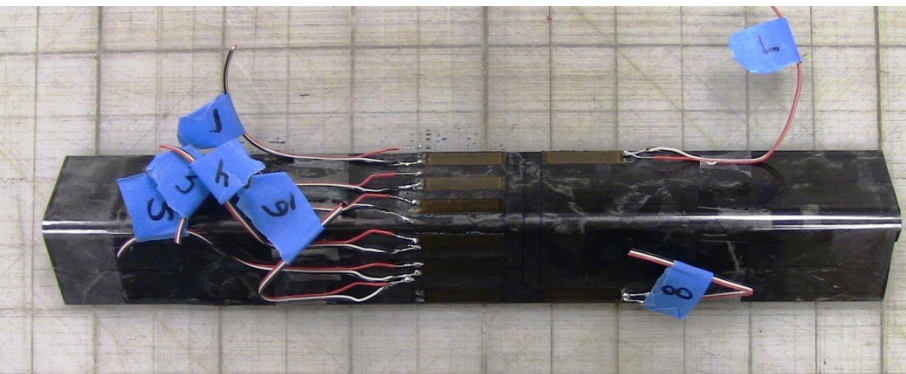



# Bending Test Fixture

All beams tested in 4-point bending

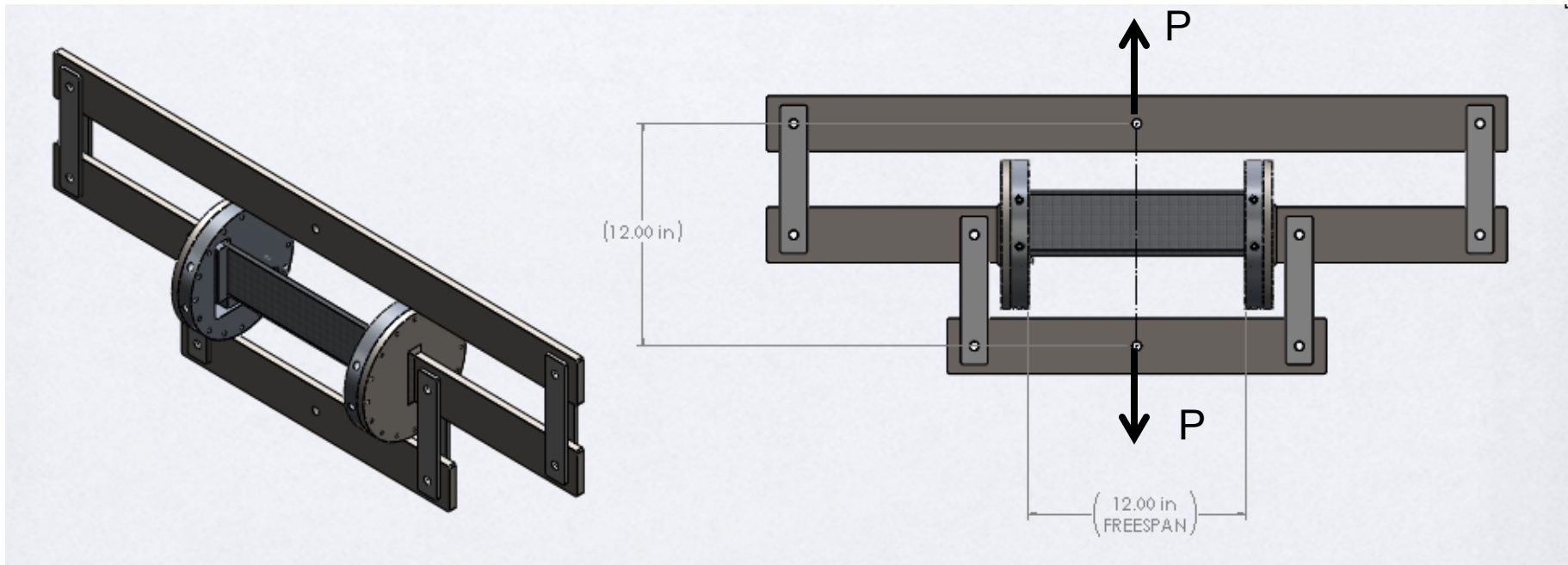

# Elastic Bending Tests

## Stiffnesses Measured in 6 Orientations

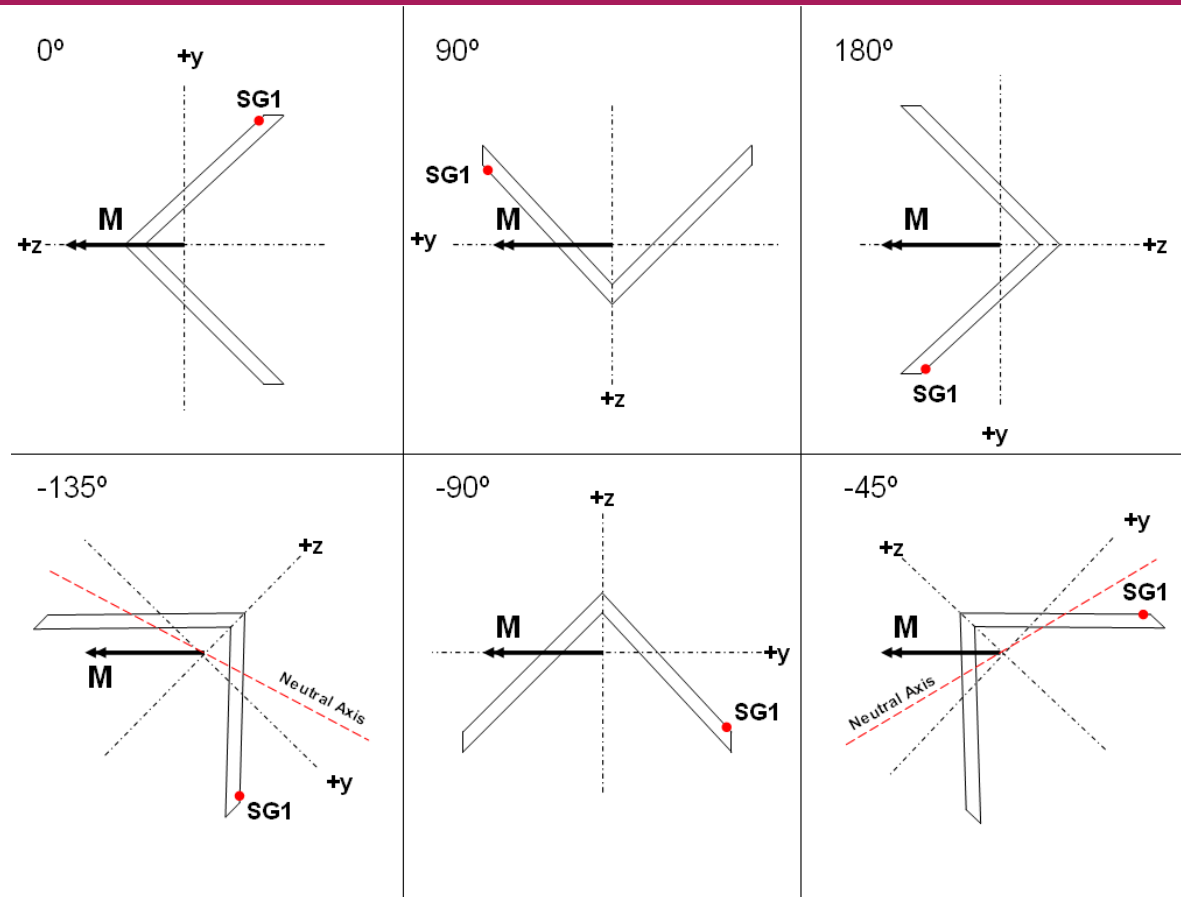

(3 beam sizes) x (3 replicate tests) x (6 orientations) = 54 tests

# Typical Measurements

## Large beam at $-135^\circ$

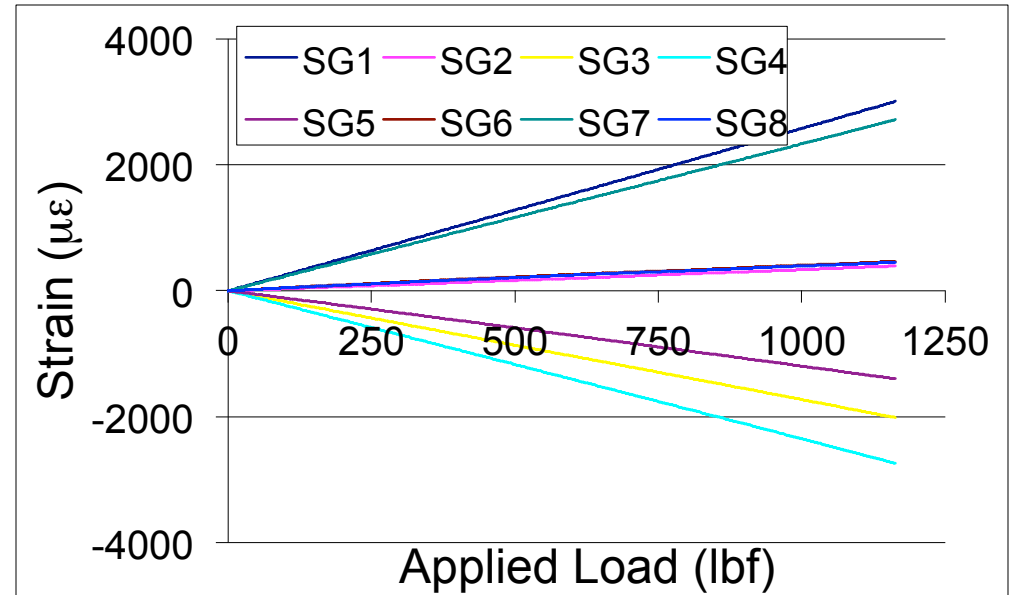
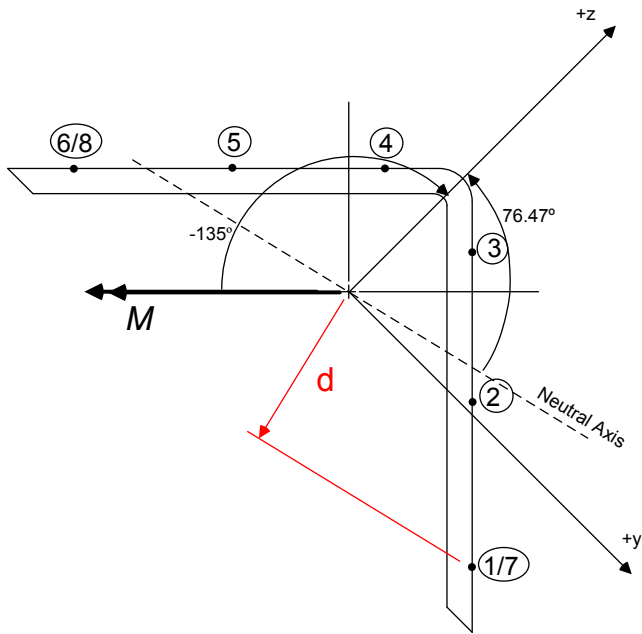

To obtain a quantitative comparison with theory:

- Slope of strain vs load ( $\mu\epsilon/P$ ) obtained for each gage using linear regression
- Values of measured and predicted slopes ( $\mu\epsilon/P$ ) were plotted against distance  $d$  from predicted neutral axis for each gage

# Typical Measurements

*Large beams at -135°  
 (3 replicate tests)*

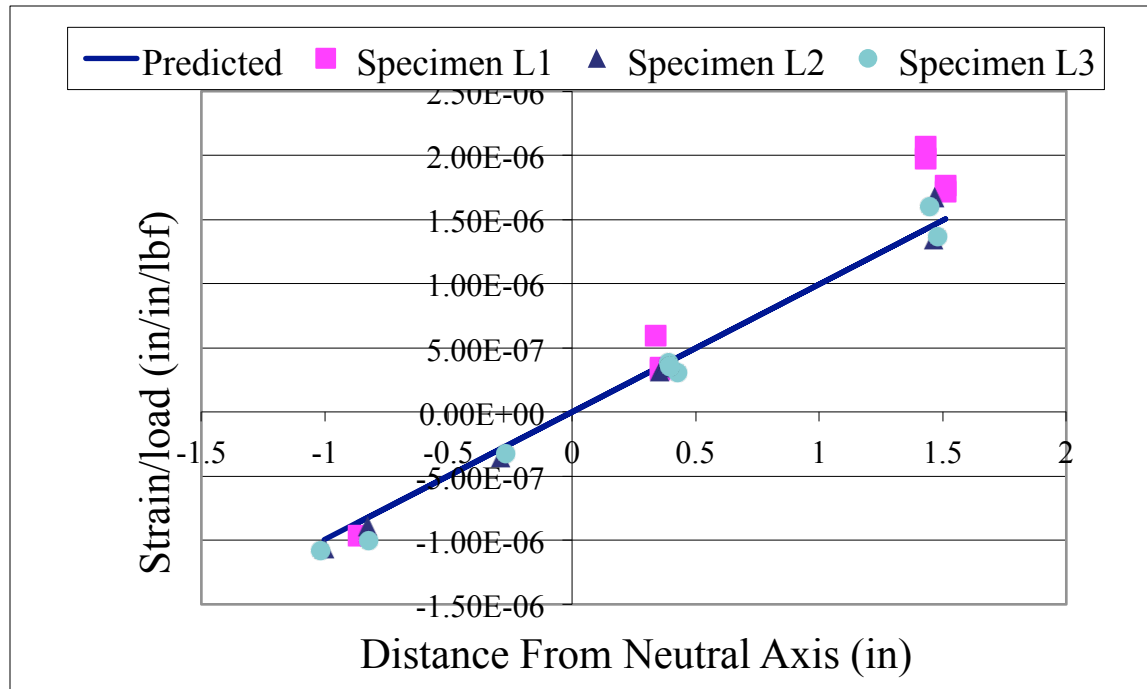

Prediction based on  
 $E = 6.38 \text{ Msi}$

as reported by Feraboli et al, Composites:Part A (2009). Note: they report a CV=19%

$E = 6.38 \pm 1.21 \text{ Msi}$

# Measurement vs Prediction

## 3 replicate large beams at 6 orientations

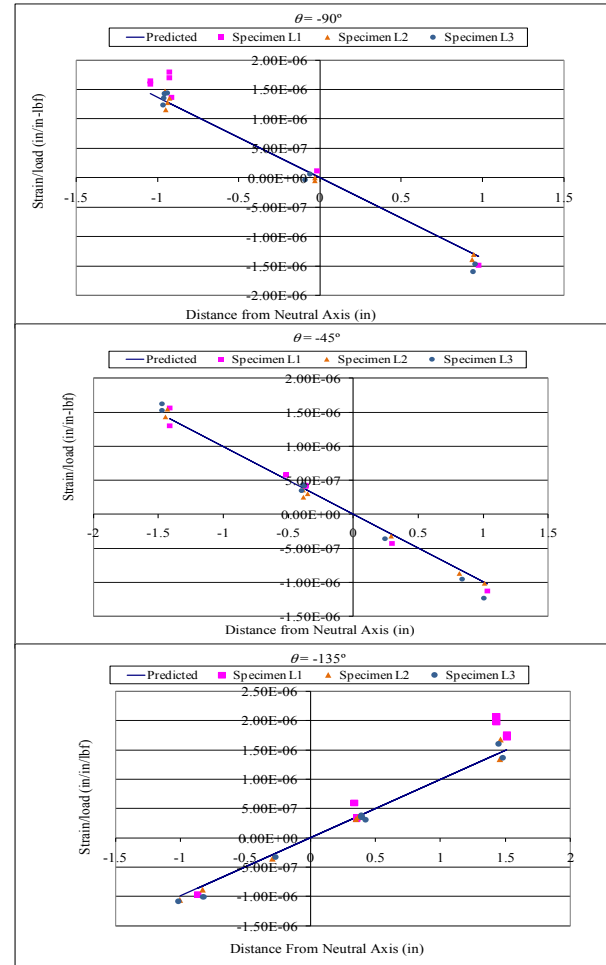
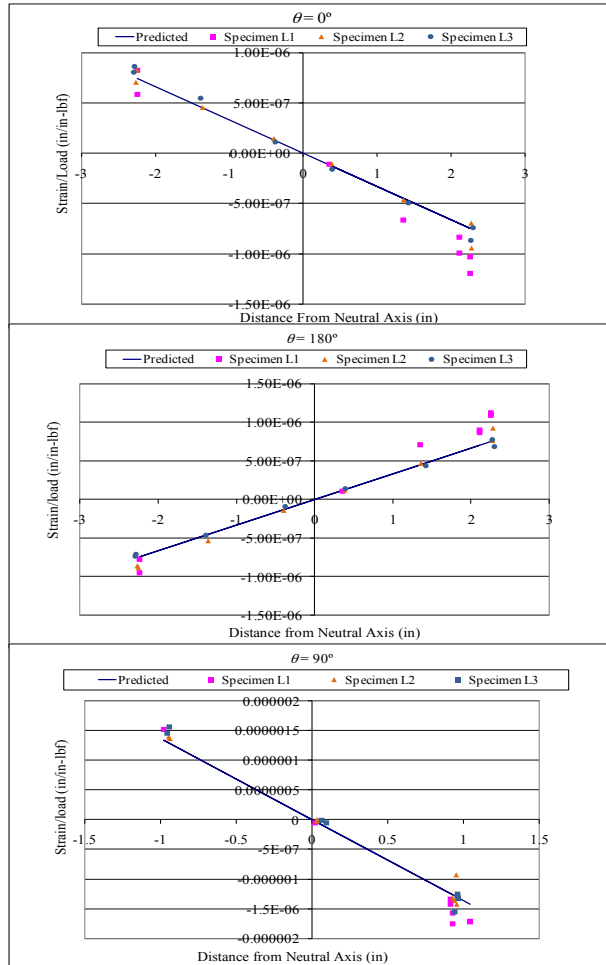

# Measurement vs Prediction

## 3 replicate medium beams at 6 orientations

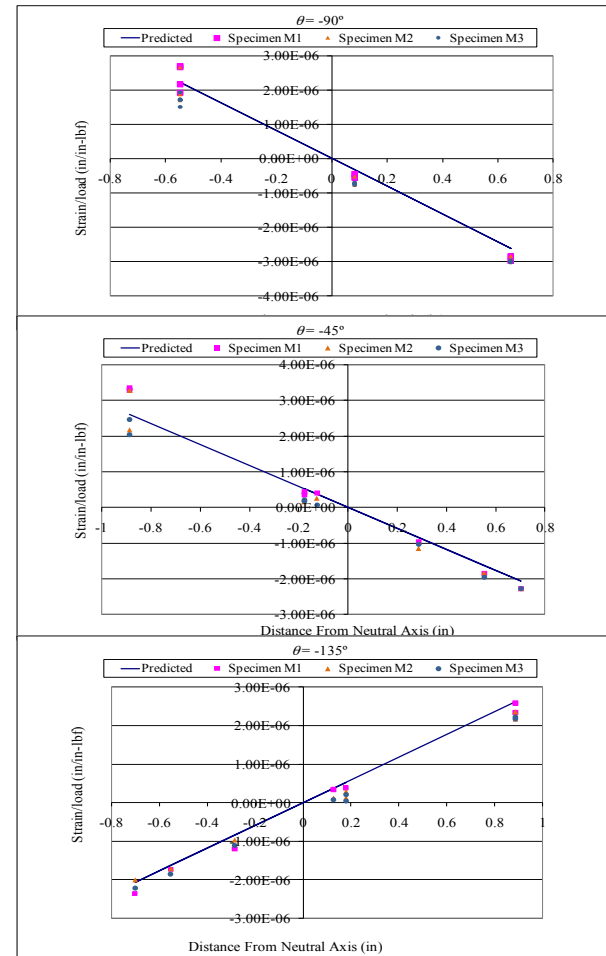
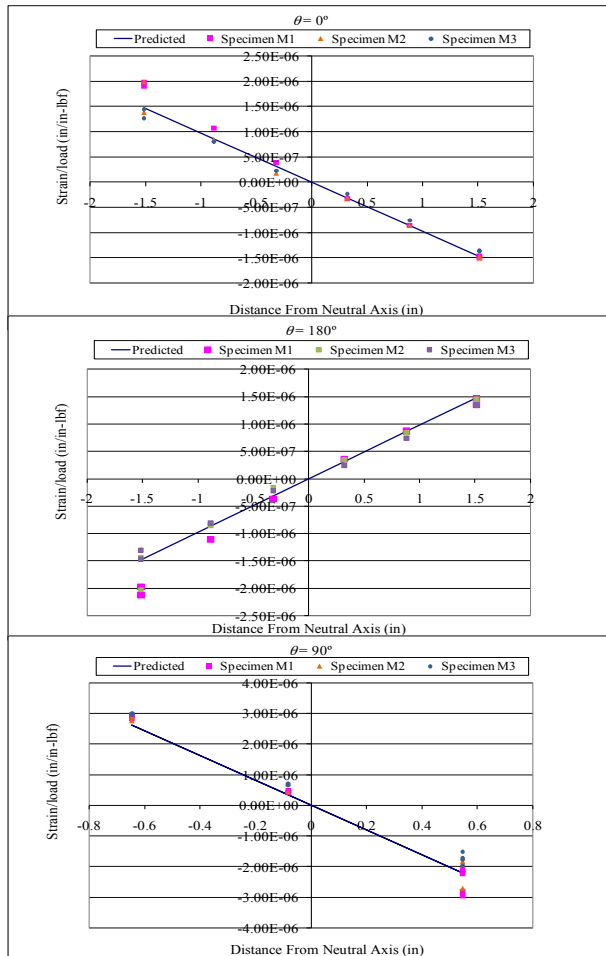

# Measurement vs Prediction 3 replicate small beams at 6 orientations

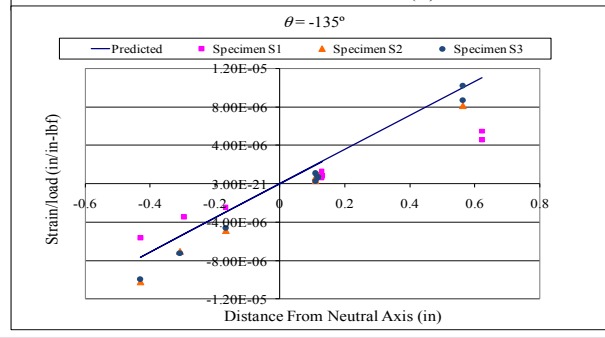
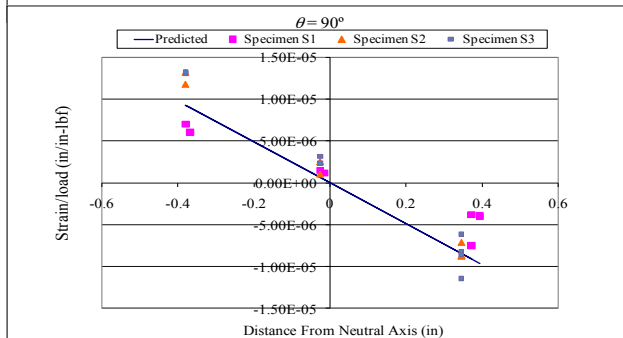
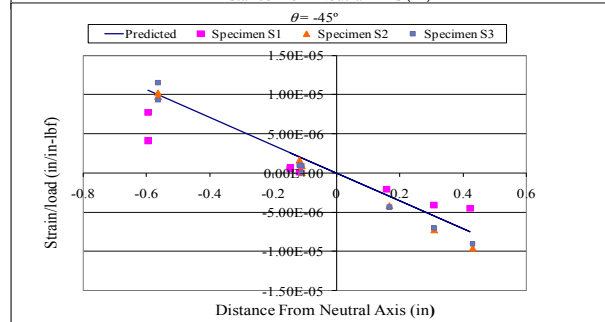
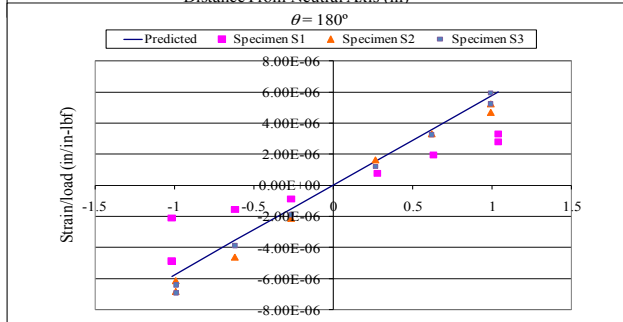
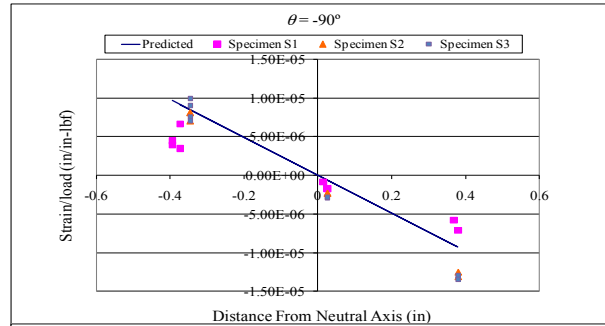
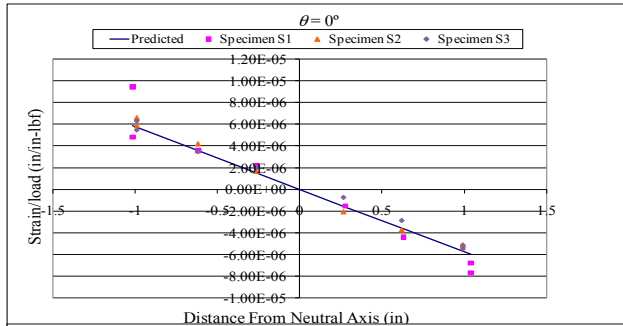

Note: one small beam (specifically, specimen S1) had significantly higher errors than all other beam specimens

# Best Fit of Elastic Modulus

- An optimization scheme was developed to identify the value of  $E$  that resulted in the best fit to the measured data
- The best fit modulus was subsequently compared to values measured during coupon tests, as reported by Feraboli et al in 2009
- Basic function: search for value of  $E$  that minimizes:

$$\left\{ \left( \frac{\varepsilon}{P} \right) \Big|^{meas} - \left( \frac{\varepsilon}{P} \right) \Big|^{pred} \right\}^2$$



# Best Fit of Elastic Modulus

## 3 "types" of best fit

- Based on 8 strain gage measurements of individual beam at single orientation:

$$\sum_{i=1}^8 \left\{ \left( \frac{\varepsilon}{P} \right)_i^{meas} - \left( \frac{\varepsilon}{P} \right)_i^{pred} \right\}^2$$

- Based on 8 strain gage measurements of individual beam at all 6 orientations:

$$\sum_{j=1}^6 \left[ \sum_{i=1}^8 \left\{ \left( \frac{\varepsilon}{P} \right)_i^{meas} - \left( \frac{\varepsilon}{P} \right)_i^{pred} \right\}^2 \right]_j$$

- Based on 8 strain gage measurements of individual beam at 6 orientations, using 3 replicate beams:

$$\sum_{k=1}^3 \left[ \sum_{j=1}^6 \left[ \sum_{i=1}^8 \left\{ \left( \frac{\varepsilon}{P} \right)_i^{meas} - \left( \frac{\varepsilon}{P} \right)_i^{pred} \right\}^2 \right]_j \right]_k$$

# Best Fit of Elastic Modulus

## 3 types of "best fit"

Specimen	Best Fit Elastic Modulus (Msi)							All Orientations
	Beam Orientation							
	0°	-45°	90°	-90°	-135°	180°		
S1	12.10	11.20	11.50	11.80	12.70	12.30	11.80	
S2	6.52	6.14	5.83	6.99	6.42	6.46	6.35	
S3	6.86	6.17	5.64	5.72	6.37	6.25	6.01	
All small beams, all orientations							7.49	
Beams S2 & S3 only, all orientations							6.16	
M1	5.76	5.66	5.89	6.10	6.61	5.67	6.00	
M2	6.27	5.66	6.70	6.70	7.34	6.30	6.58	
M3	7.25	6.44	7.08	7.09	7.24	7.23	7.05	
All medium beams, all orientations							6.52	
L1	5.27	6.30	5.53	5.59	5.24	5.04	5.51	
L2	6.36	6.48	6.59	6.45	6.37	5.86	6.42	
L3	6.42	6.60	6.70	6.56	6.44	5.92	6.52	
All large beams, all orientations							6.07	

Specimen S1 was an "outlier"

# Best Fit of Elastic Modulus

*Comparison to values from coupon tests*

Best Fit Modulus Based on all Orientations

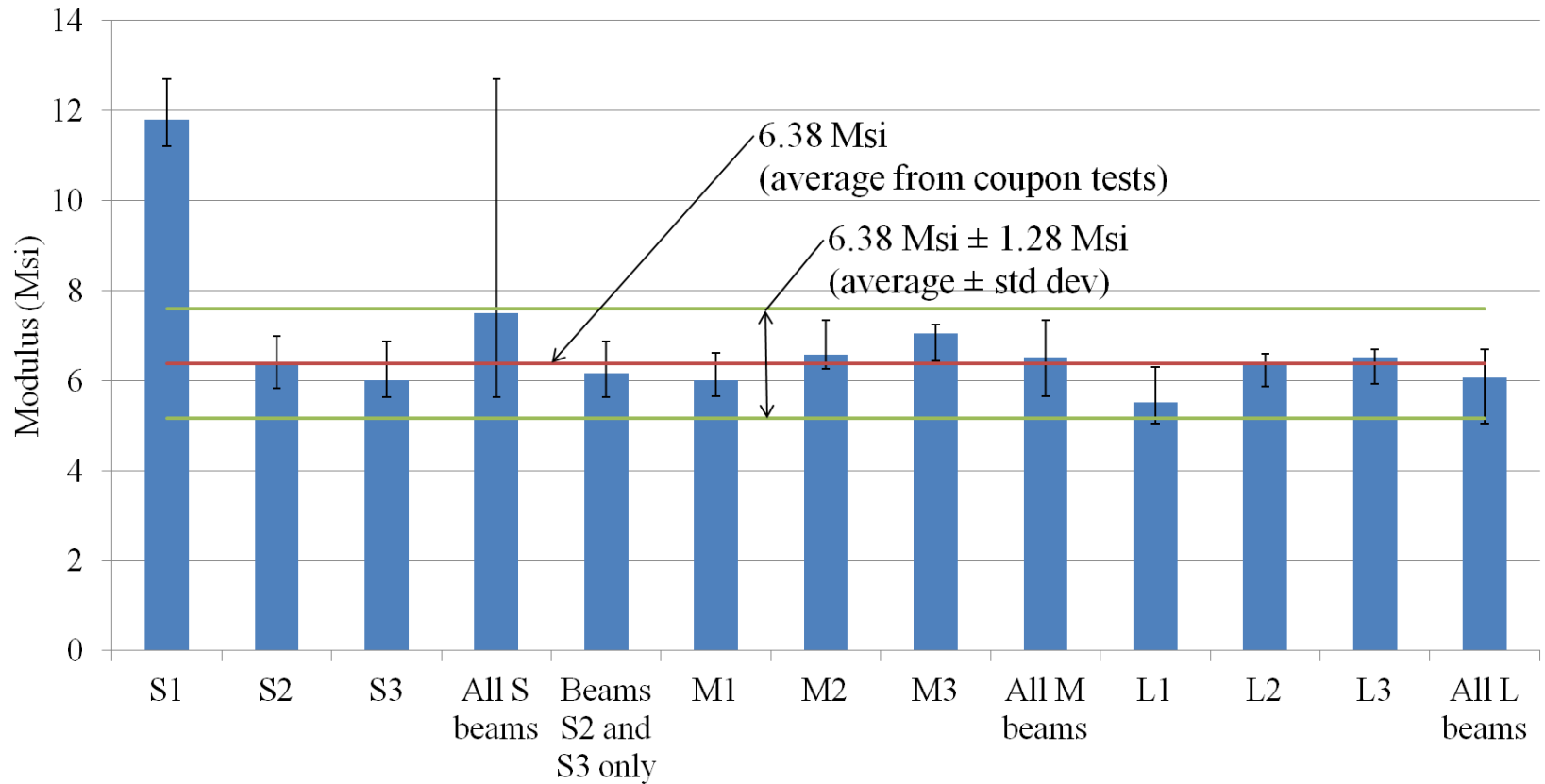

# Elastic Bending Stiffness *Conclusions*

---

Elastic bending stiffnesses of HexMC beams were reasonably well-predicted by treating HexMC as an isotropic material

Scatter in best fit modulus measurements inferred from beam bending tests comparable to scatter inferred from coupon tests

---

# Bending Tests to Failure

- Beam oriented at  $180^\circ$  in all cases
- Applied loading (bending moment) increased until failure occurred
- Test conducted using constant crosshead rate (0.05 in/min)

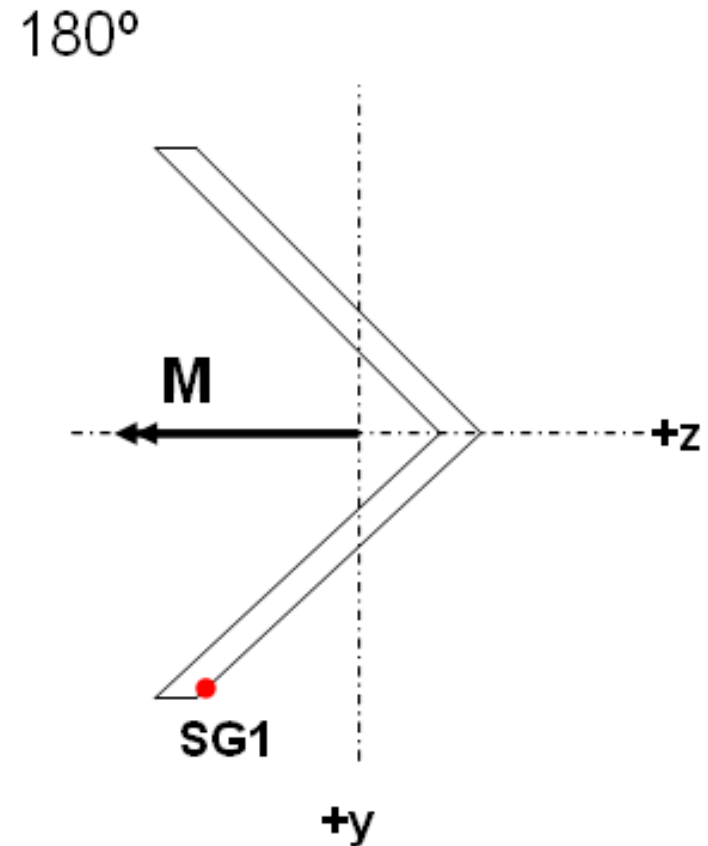

# Bending Tests to Failure *Specimen L2*

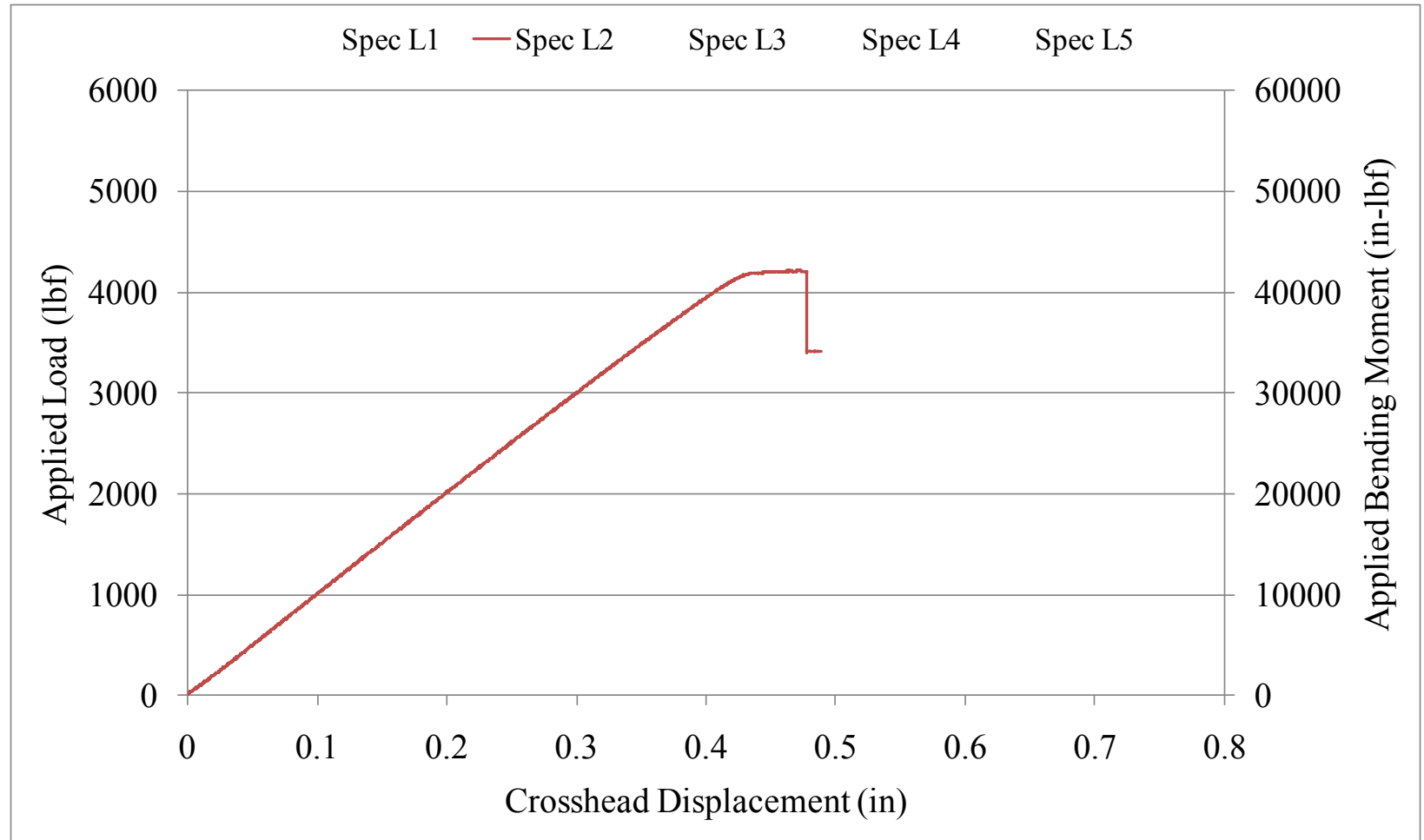

# Bending Tests to Failure Specimen L2

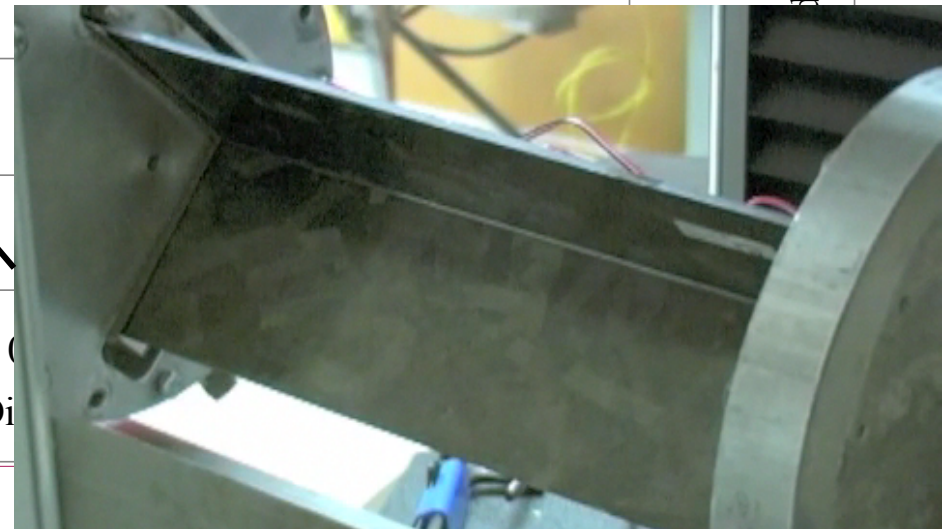
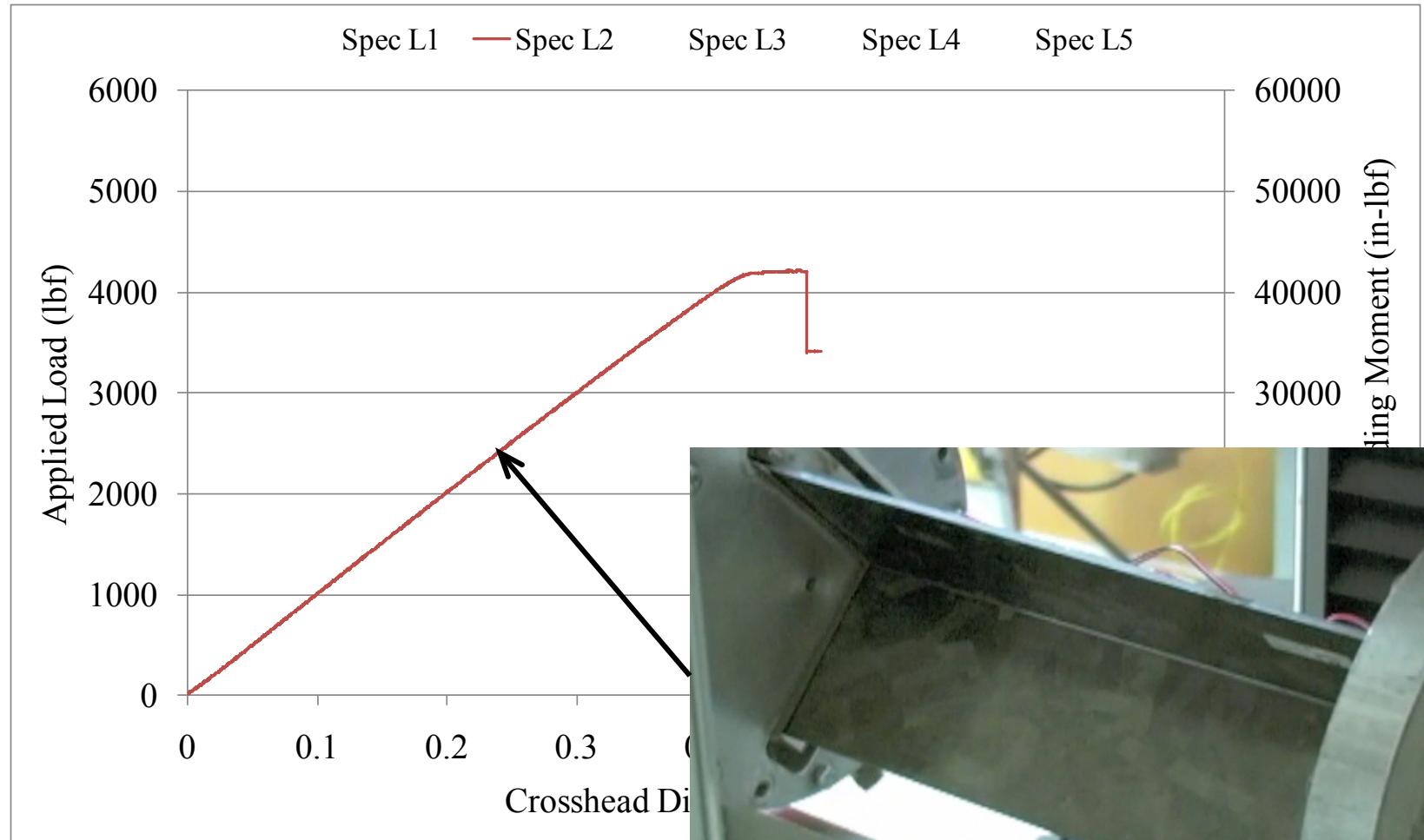

# ing Tests to Failure *en L2*

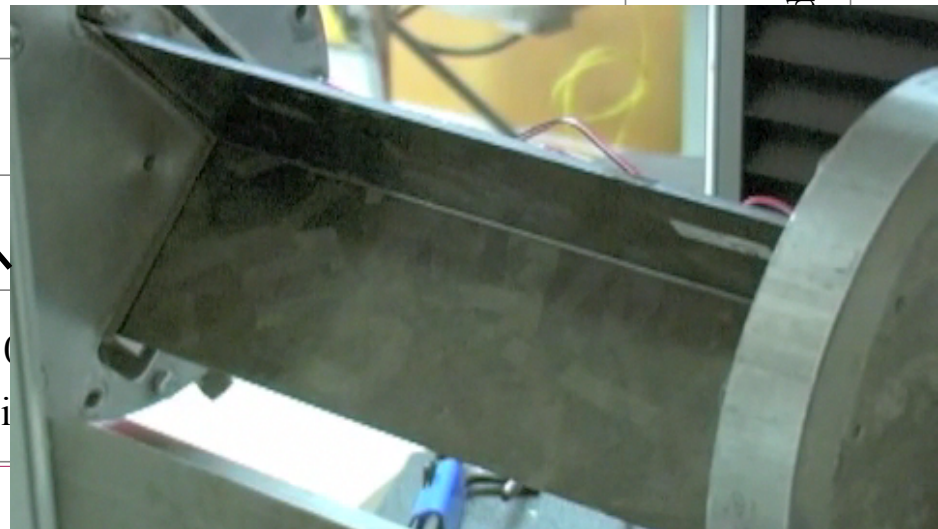
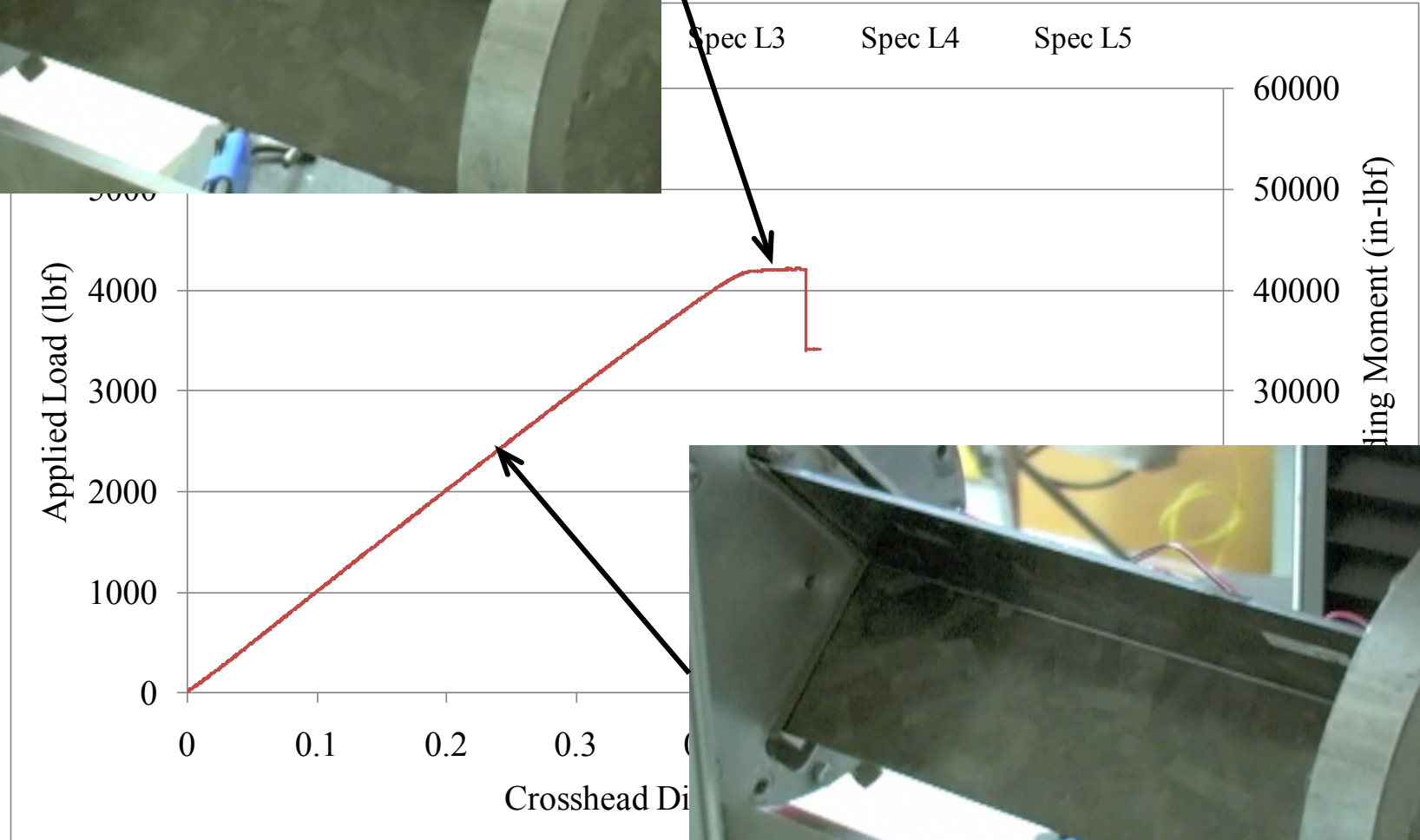
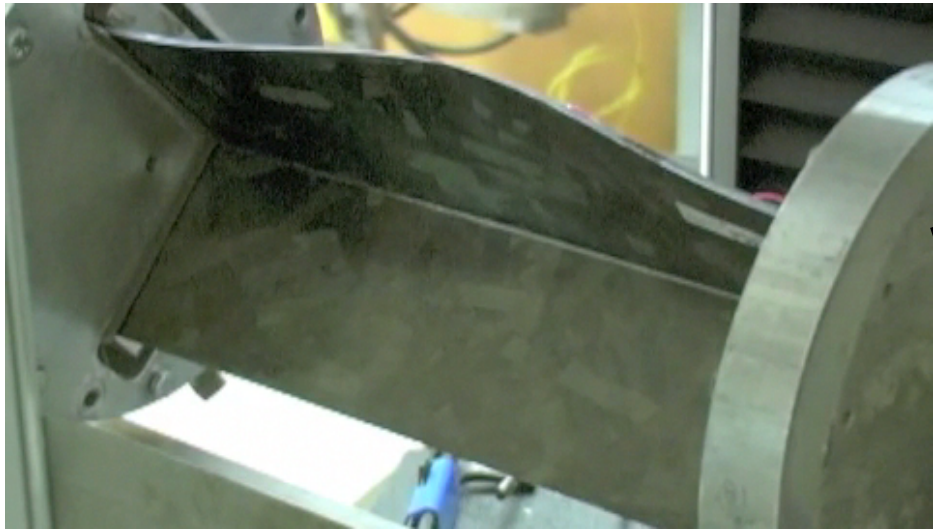



# Bending Tests to Failure

## 5 Replicate Large Specimen Tests

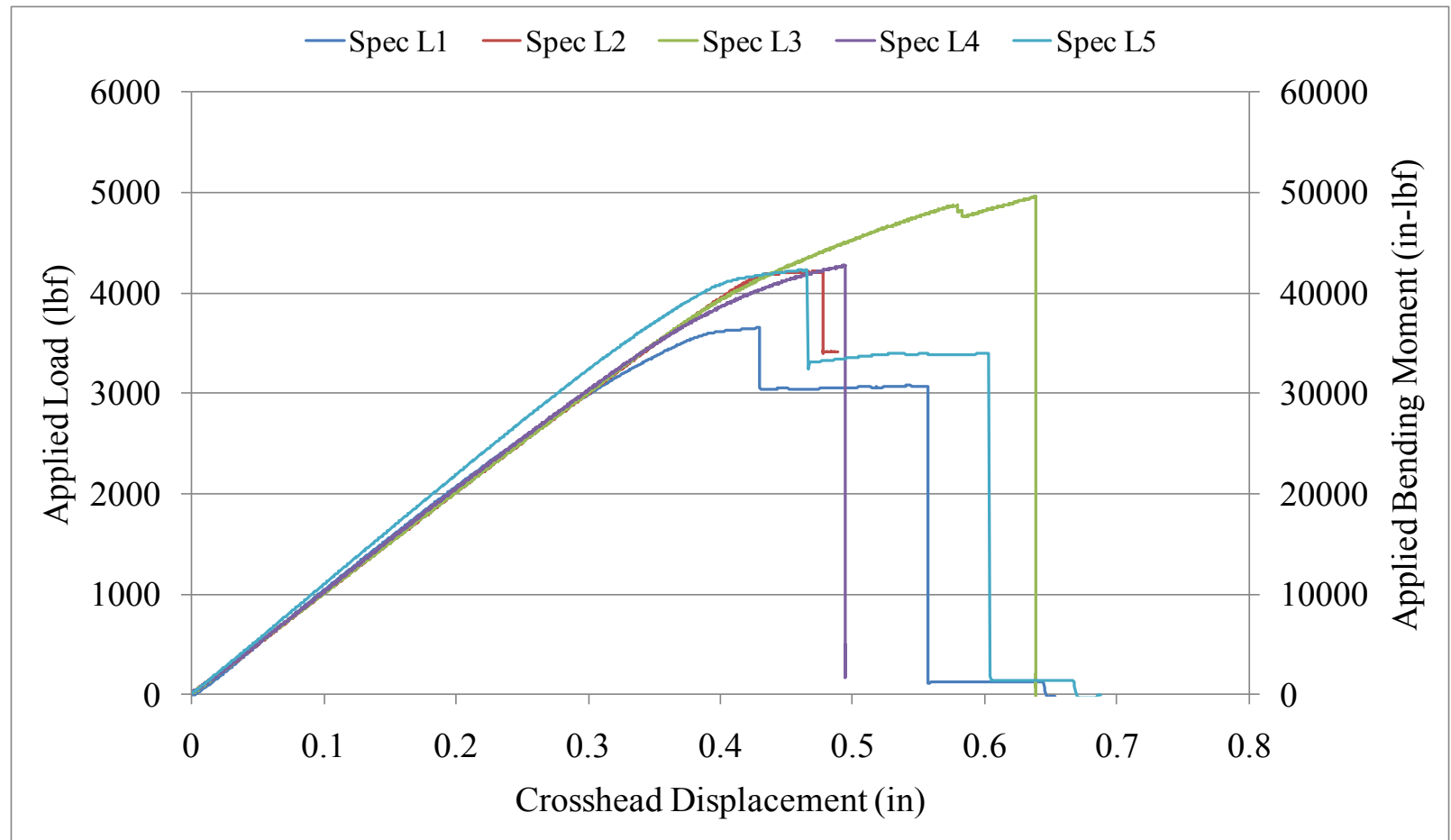

# Bending Tests to Failure

## 5 Replicate Large Specimen Tests

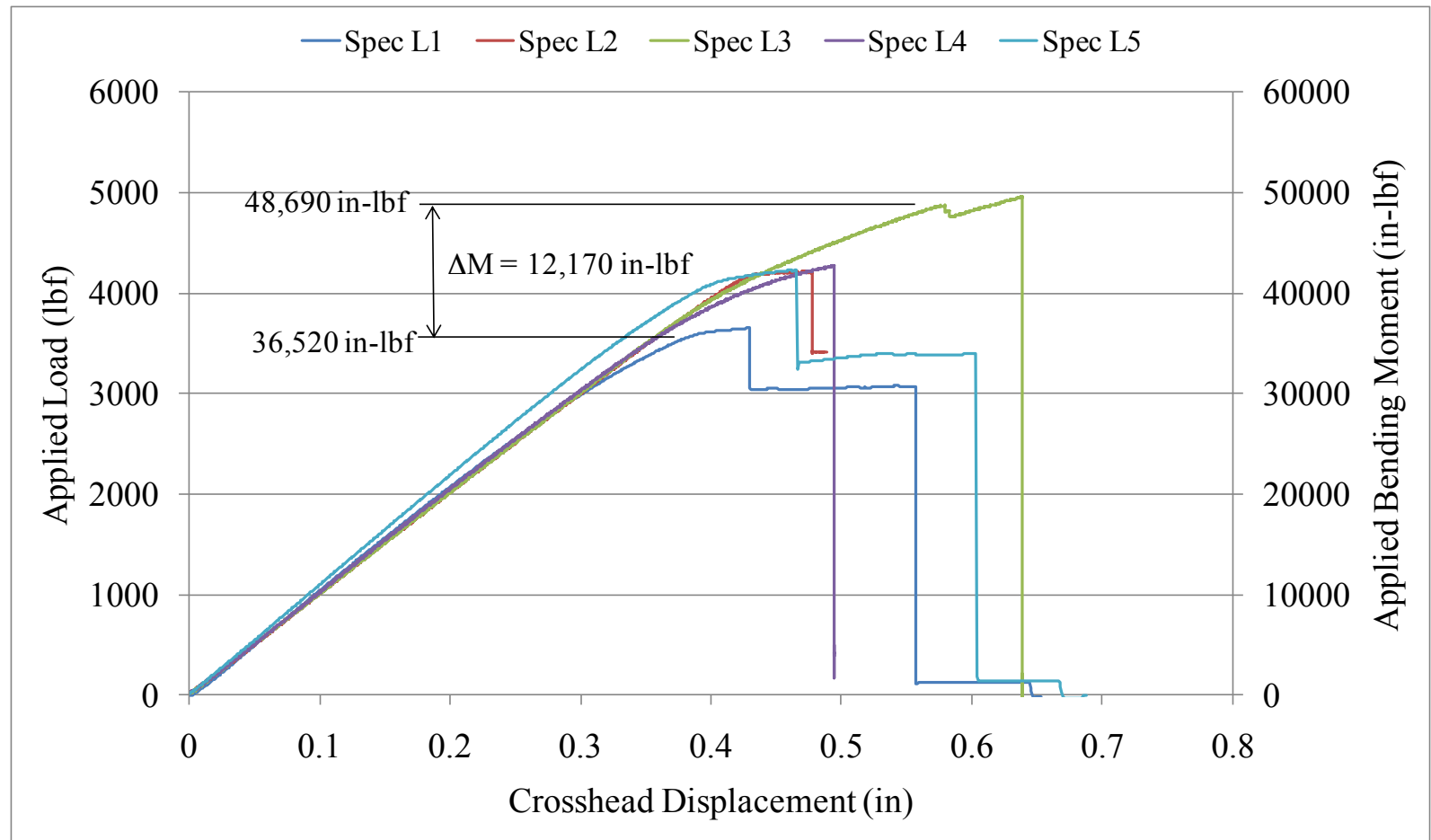

# Bending Tests to Failure

## 5 Replicate Small Specimen Tests

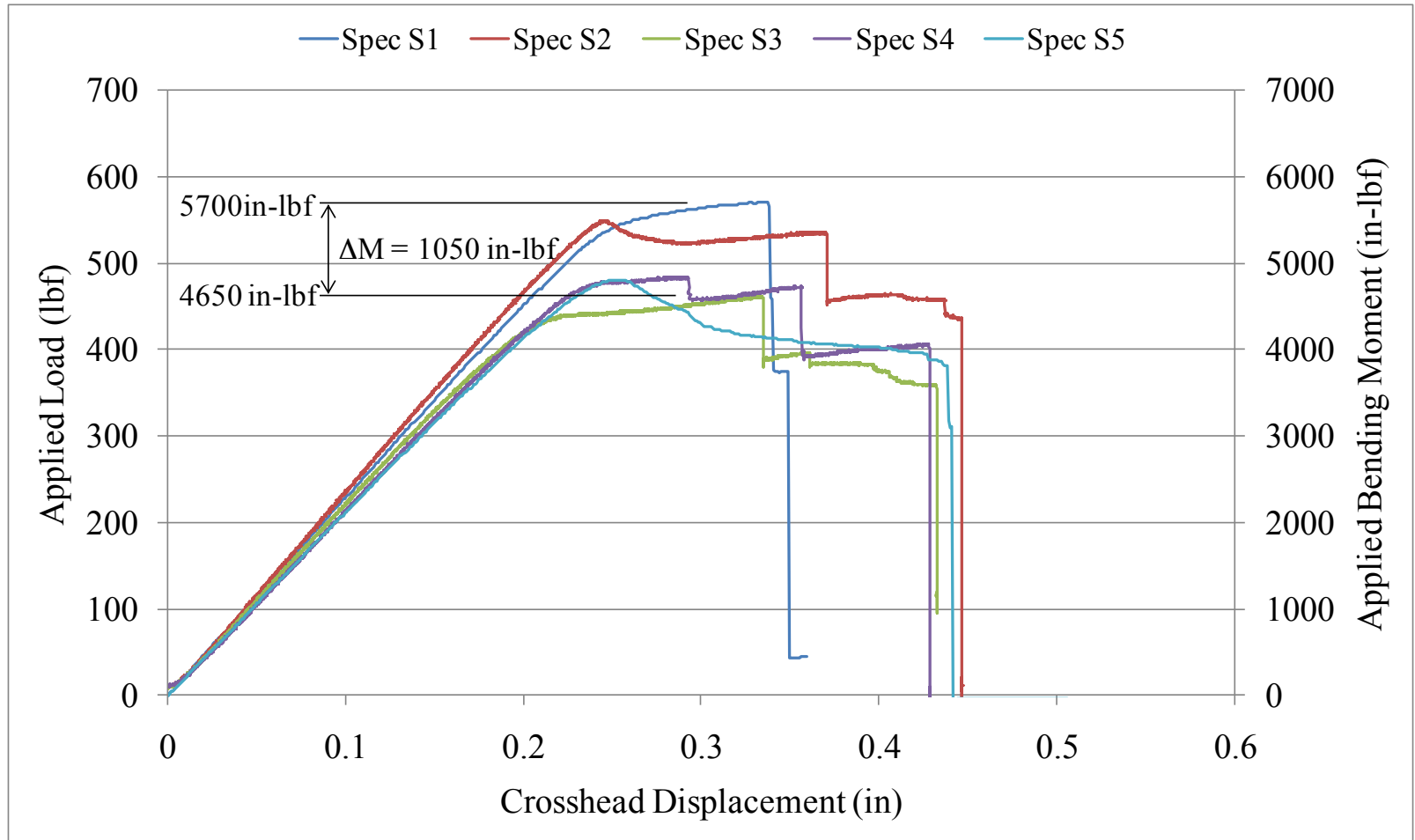

# Bending Tests to Failure

## 6 Replicate Medium Specimen Tests

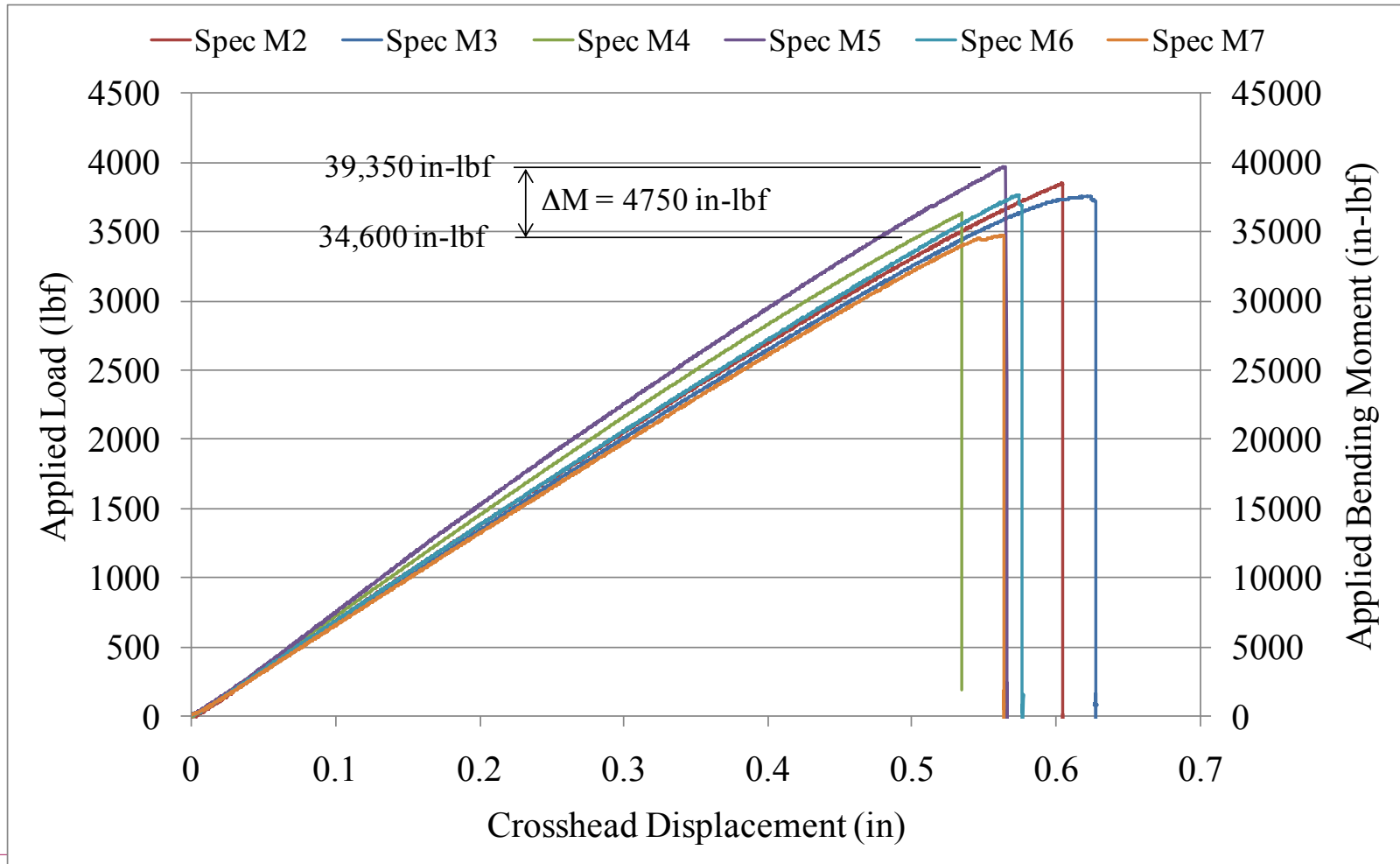

# Bending Tests to Failure

## *Summary observations...*

---

- The large and small beams exhibited a pronounced buckling/crippling behavior well before final fracture. Final fracture was a post-buckling *bending* failure of compressive flange.
  - For the medium beam the bending moment necessary to cause buckling was nearly equal to the bending moment necessary to cause tensile/compression fracture of the flanges; for the 6 medium beams tested to failure:
    - Three failed prior to significant buckling behavior
    - Three failed shortly after buckling initiated
-

# Bending Tests to Failure

## *FEA Analyses*

- Tory Shifman performed preliminary analysis using ANSYS
- Brian Head will expand FEA analyses for all beam sizes and for varying E's using NASTRAN

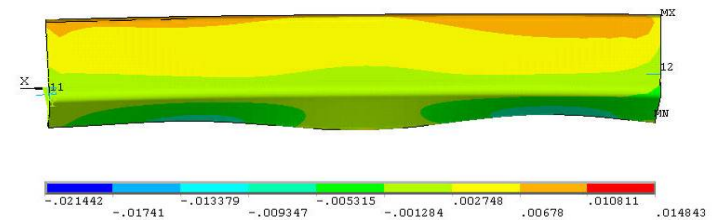
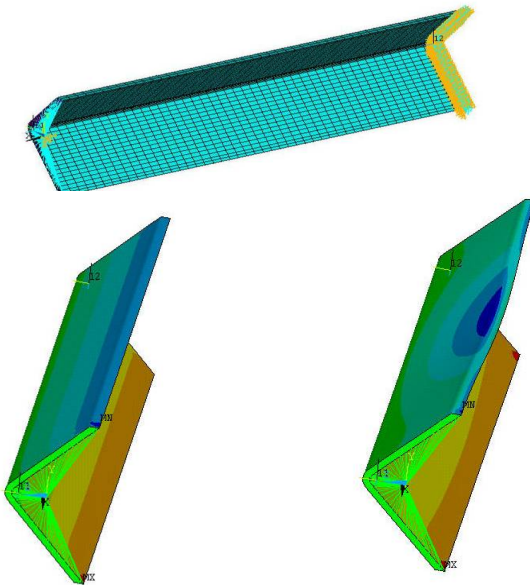

# Bending Tests to Failure

## *FEA Analysis*

---

- Based on experimental observations, it is hypothesized that for modulus values ranging from

$$5.10 \text{ Msi} \leq E \leq 7.66 \text{ Msi}$$

(i.e., for  $E = E_{\text{avg}} \pm \text{Std Dev}$ )

the NASTRAN analyses will show:

- Large and Small beams: buckling/crippling predicted to occur prior to reaching bending moment levels necessary to cause failure stress/strain levels
  - Medium beams: buckling condition and failure stress levels are reached at “about” the same bending moment level
-

## HexMC Intercostals

- HexMC intercostals are stiffeners used near the door structures in the B787 fuselage
- In the UW tests intercostals will be loaded as cantilever beams

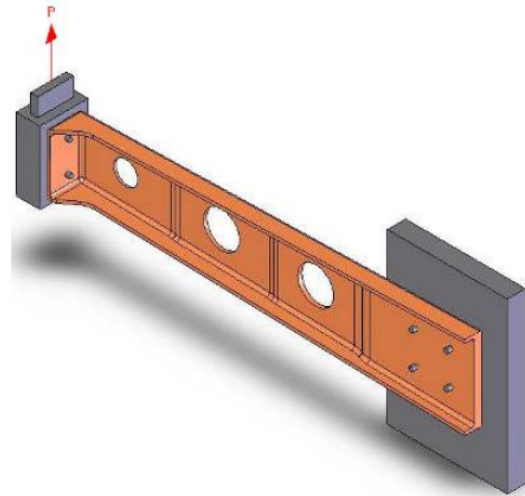



# Intercostal Test Frame

*Designed at built at the UW*

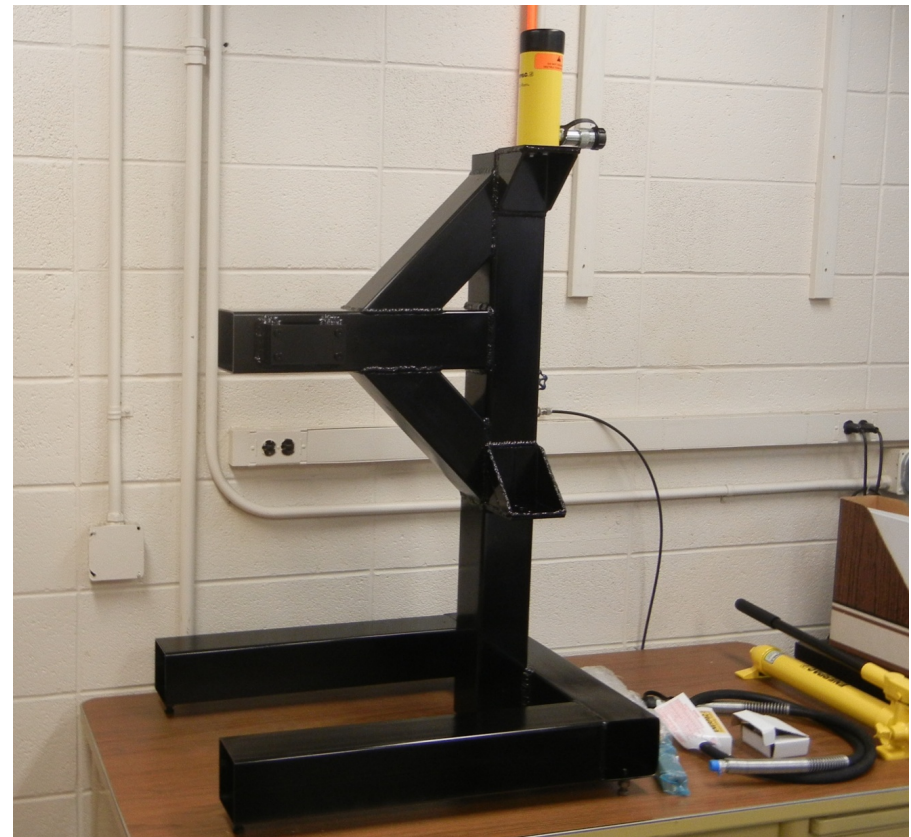
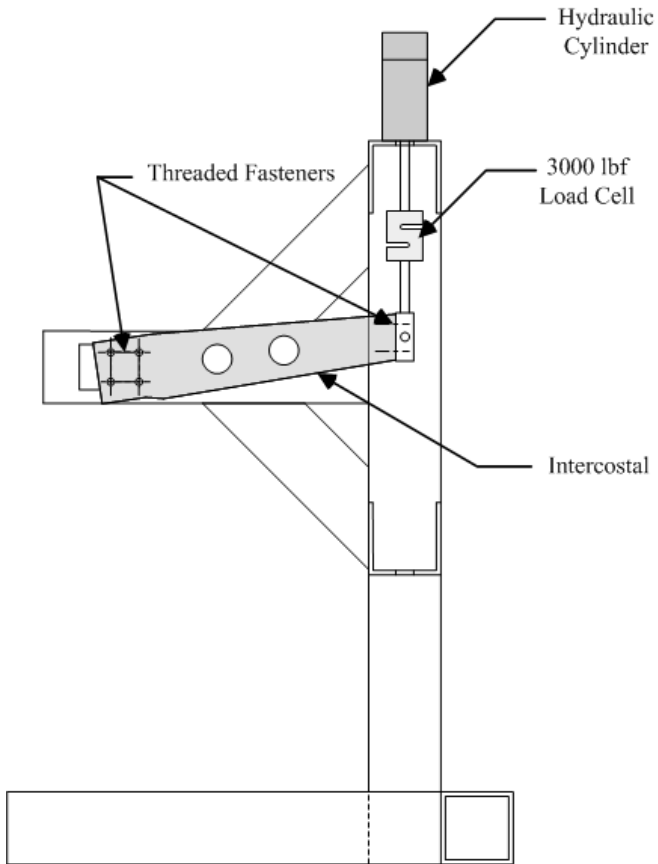

# Intercostal Test Frame

*Designed at built at the UW*

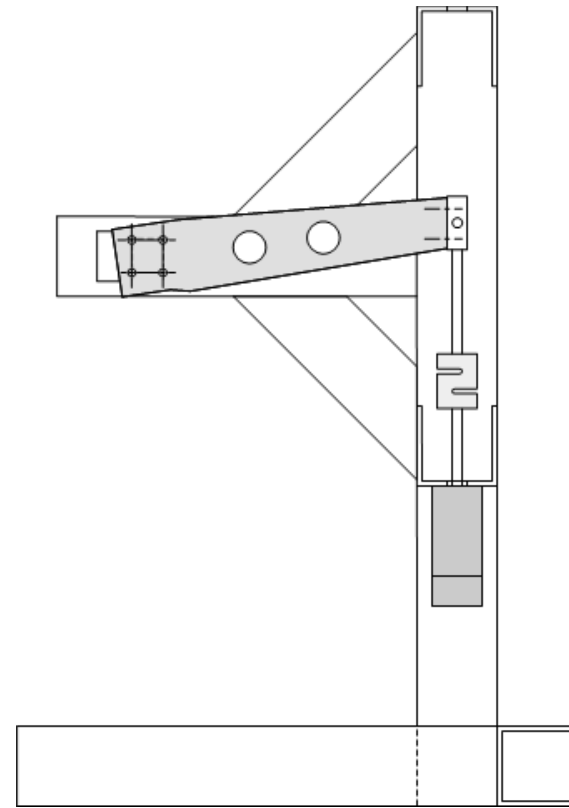
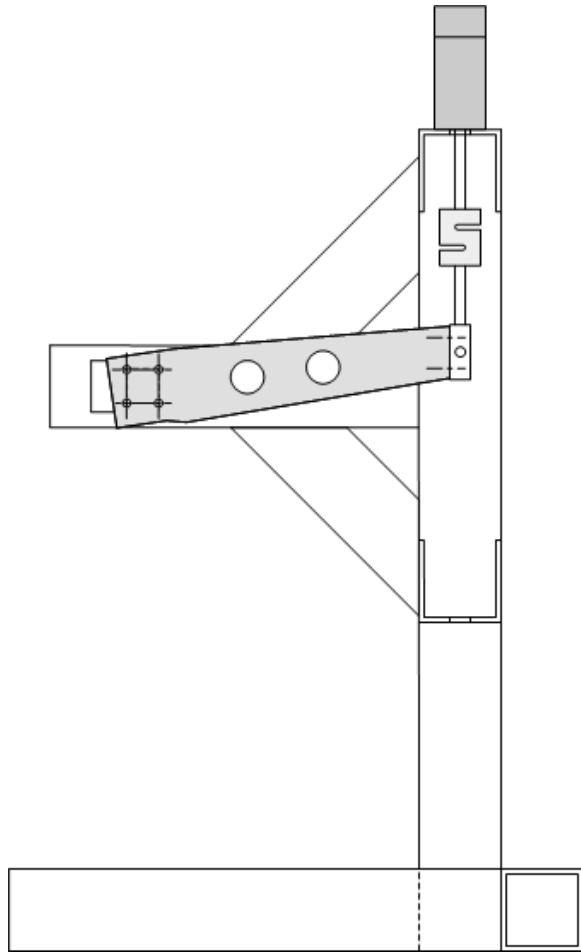

# Intercostal Test Frame

*Designed at built at the UW*

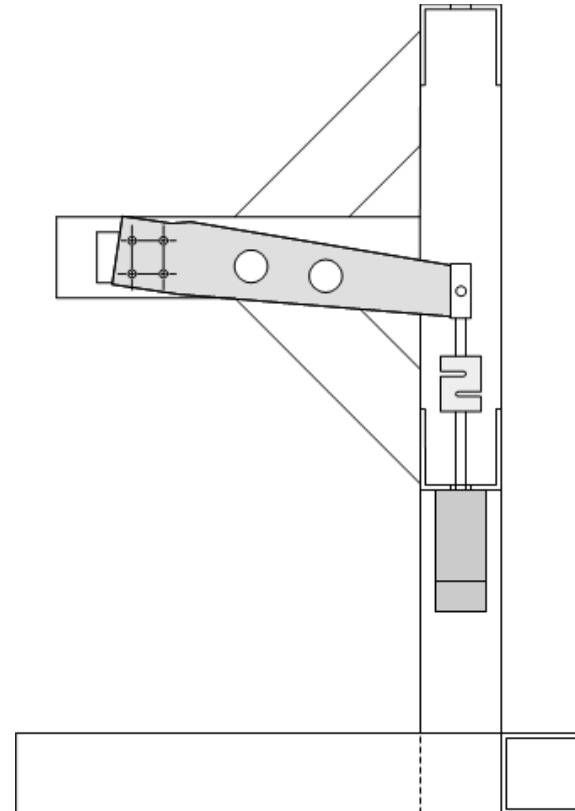
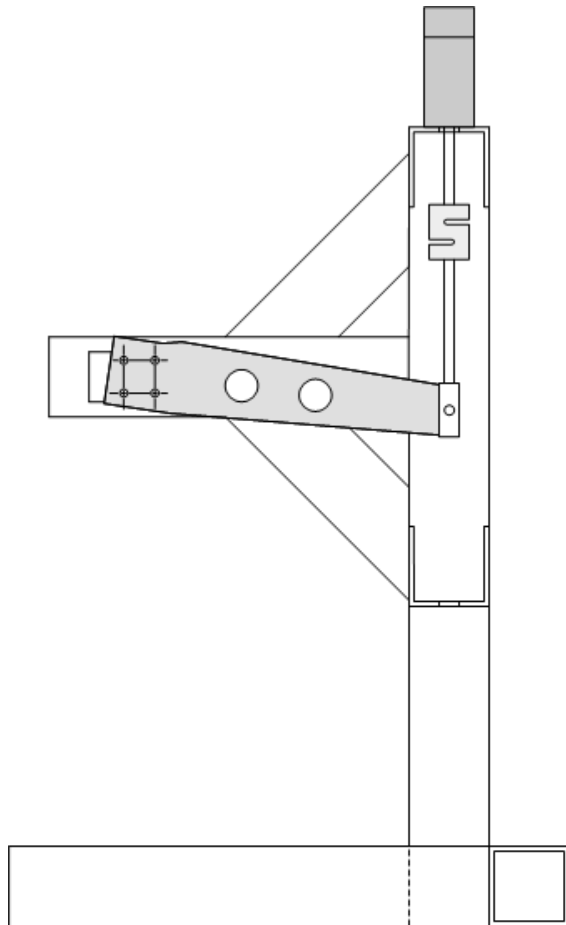

# Intercostal Testing and Analysis

---

- Testing will begin during November; strains will be measured using both
    - 1-in strain gages
    - Digital Image Correlation
  - FEA analyses will be performed using NASTRAN
  - Tests and analyses expected to be completed by Spring 2012; results will be presented at
    - 2012 JAMS meeting
    - 2102 fall AMTAS meeting
-

Thank you for your  
attention!

Comments or Questions?

---